

ART380 TELEPHONE INTERFACE MANUAL



VIDEX

Installation and programming manual

Version 1.4

06/2006

CONTENTS

DESCRIPTION	PAGE
Introduction	3
Mounting Instructions	3
Safety notes	3
Connections to the telephone line	3
Dealing with other telephone equipment	4
Dealing with Broadband	4
Wiring directions	5
Connecting more than one handset	6
Lock release back EMF protection	6
Cable size	7
Jumper setting	7
Programming overview	7
Tones overview	8
Initial setup	9
Optional call adjustments	10
Setting the auxiliary outputs	10
Advanced speech setup options	11
Dial in facility setup	11
Divert call setup	12
Access code setup	13
Specialised setup	13
User commands	14
Approval	14
Troubleshooting	15
Specification	15
Telephone connection examples	16
Wiring diagram 1 (837M amplifier)	17
Wiring diagram 2 (837 amplifier)	18
Wiring diagram 3 (VK6N)	19

Introduction

The Art380 is a self contained telephone interface module for use on an analogue telephone line. Its primary function is to enable a user to communicate with a telephone line and a door entry point (or points) from the same telephone handset. This handset can be a standard corded model, a cordless such as a DECT telephone or even a hands free telephone. The Art380's main features are listed below:-

- Communicate with both a telephone line and door entry points.
- Open a door using the telephone keypad.
- Open the speech to a door entry point without first being called.
- Activate up to two auxiliary outputs. (Outputs can be either momentary or latching).
- Reverse the door open relay for use with power to lock releases.
- Make the following call adjustments in programming mode:-
 - Number of rings (From 1 – 10 rings)
 - Door open time (From 1 – 18 seconds)
 - Door open key (Either 0(default), 8 or 9)
 - Internal/external speech volume.
- Divert the call to another pre-programmed number.
- Program an access code to protect the programming and the use of facilities in either divert mode or normal mode.
- Operate in a hands free mode (Speech automatically adjusts the gain to the direction of speech).
- One way speech mode (Simplex speech)
- PABX mode (Allows the units to operate without the need for a telephone line).
- Dial in facility which allows the Art380 to be activated from an incoming telephone call.

Mounting instructions

The Art380 can be either mounted to a DIN rail or mounted directly to a wall. Begin by removing the terminal side covers by unscrewing the retaining screws. Either clip the Art380 to a DIN rail or screw directly to the wall using two screws and suitable wall plugs. You should leave the terminal side covers off until all connections have been made.

Safety notes

The system must be installed by a competent installer following the regulations in force. We recommend:-

- Use an appropriate fused spur to isolate the mains from the Art380.
- Isolate the mains before removing any covers from the system (Please note: There are no user serviceable parts within the Art380 and so the covers should only be removed by a competent technician).

Connections to the telephone line

Each telephone line coming into your home or office must be fitted with a six pin primary socket installed by the PTO (Public Telecommunication Operator). It is illegal to tamper in any way with this primary socket and you can't install it yourself. Additional connections to the primary socket must be carried out using a BT style plug (You cannot connect directly to the

terminals inside). The ART380 telephone interface unit is supplied with a BT style plug. For more information, see relevant paper work supplied with extension sockets.

When connecting additional equipment to a telephone line it is good practise to first check the equipment already installed by previous engineers. This includes any additional secondary sockets, digital set top box such as Sky Digital, faxes, modems, Broadband and REDCARE alarm monitoring etc. The following precautions should be observed when connecting to any of the named above:-

Secondary sockets

If secondary sockets are installed, open each one and check it is a secondary socket and not another master (A secondary socket will not contain any components whereas a master socket will have a capacitor, resistor and suppressor fitted). Only one master socket should be connected after the Art380. If there are more than one fitted they must be replaced with secondary (Slave) sockets. (Also note: The Art380 is only capable of ringing two handsets with a REN value of 1 each).

Sky Digital, Faxes, Redcare and modems

Sky digital, fax machines, Redcare or any other form of telephone line based monitoring and conventional modems must be fitted before the Art380 and not after.

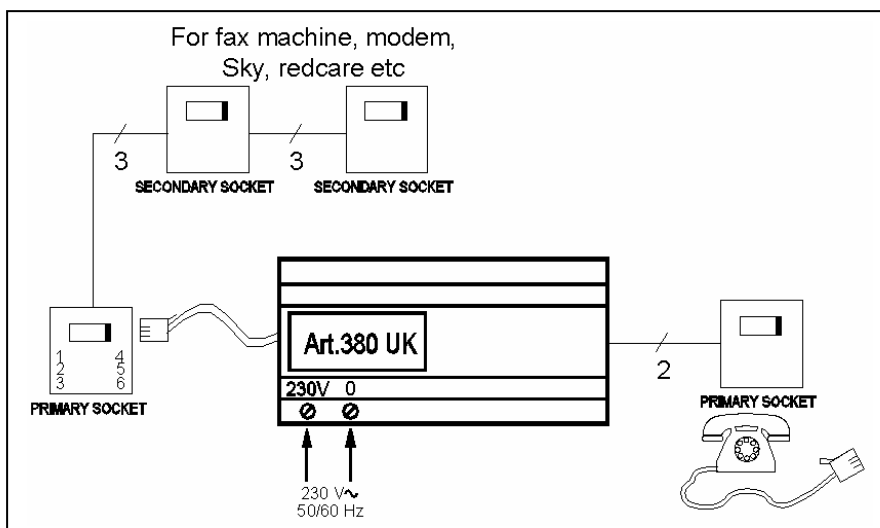

Broadband

On installations with broadband it is important to connect the Art380 into the system as shown below:-

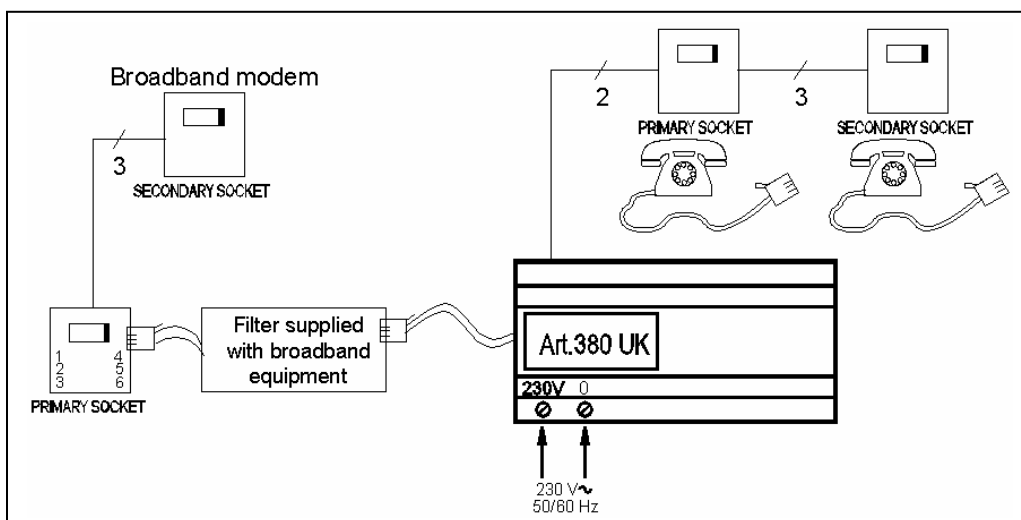

Wiring directions

Please follow the appropriate wiring diagram from one of the pages at the rear of this manual. For information purposes, the connections on the Art380 have the following functions:-

CONNECTION	DESCRIPTION	EXPECTED OUTPUT
230V	Live terminal for mains input to the device.	This should be connected to the mains via a fused spur
0	Neutral terminal for mains input to the device.	This should be connected to the mains via a fused spur
2	Receive speech from the door panel.	Approx. 8-12V DC during standby or approx. 1V DC when the speech to the door panel is open.
1	Transmit speech to the door panel	Approx. 8 – 12V DC during standby or approx. 4V DC when the speech to the door panel is open.
3	Ground	Use this connection as a reference point for voltage checks.
6	Call line to trigger a call from a door panel.	0V in standby and approx. 12V AC or DC when the call button is pressed.
C	Common connection of door open relay.	Dry contact. Continuity checks can be made between C & NO.
NO	Normally open or normally closed connection of door open relay depending on programmed state.	Dry contact. Continuity checks can be made between C & NO.
A2	Auxiliary 2 output	Open collector output. Becomes a 0V when activated. Can be either latched or momentary depending on programming. Also can be used to automatically trigger a camera depending on programming. (Max. 200mA)
A1	Auxiliary 1 output	Open collector output. Becomes a 0V when activated. Can be either latching or momentary depending on programming. (Max 200mA).
+12	+12V DC output.	Can be used to trigger a relay in conjunction with A1 or A2. Maximum current output available is 100mA.
+12	+12V DC output	Can only be used to power Videx serial bus modules designed to work with the Art380.
-	0V	0V connection. Can only be used to power Videx serial bus modules designed to work with the Art380.
SK	Clock signal	For use with Videx serial bus devices. Normally sits at 12V DC. Will alternate during data transfer.
SI	Data signal	For Videx serial bus devices. Normally sits at 12V DC. Will alternate during data transfer.

L1	Telephone line input	Can be used as an alternative connection to the RJ11 socket.
L2	Telephone line input	Can be used as an alternative connection to the RJ11 socket.
T1	Telephone output	
T2	Telephone output	

Connecting more than one handset

Up to one additional handset can be connected, using secondary telephone sockets as shown in the diagram below.

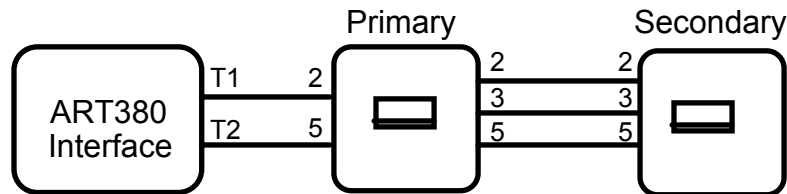

If more telephones are required. They should be connected to the Art380 via a REN booster (The REN booster is a third party product not supplied by Videx). **IMPORTANT NOTE: When using a REN boost the Art.380 must be put into PABX mode. It will then be necessary to press '0' to get an outside line.**

Lock release back EMF protection

A capacitor must be fitted across the terminals on an AC lock release and a diode must be fitted across the terminals on a DC lock release to suppress back EMF voltages. The diagrams below show how to connect these components to the lock releases.

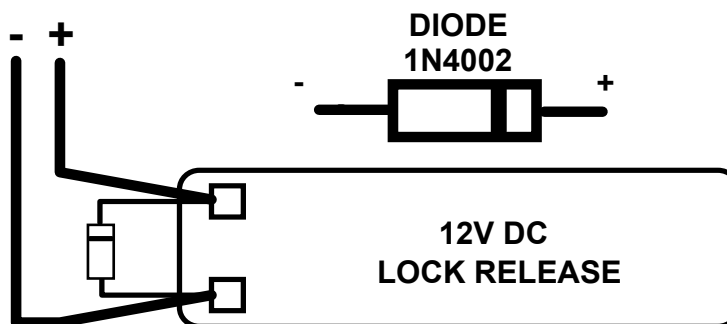
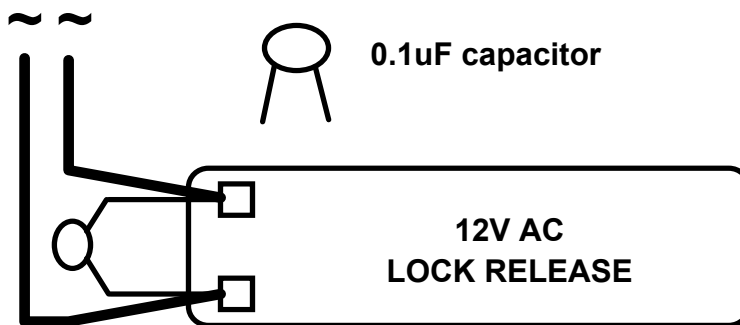

Cable size and type

When running cables for any intercom system, these cables must be installed separately from the mains cables. All multi pair cables should be to CW1308 specification. (0.5mm twisted pair telephone cable). Max resistance = 10 Ohm.

Lock release wires should be doubled up. Max resistance = 3 Ohm

The cable sizes above can be used for distances up to 50m. On distances above 50m the cable sizes should be increased to keep the overall resistance of the cable below the RESISTANCE'S indicated above.

The total length of standard telephone wiring between the primary and any extension socket must not exceed 50M. The total length from the primary socket to the furthest secondary socket must not exceed 100M.

Jumper settings

There are four jumpers on the Art380 labelled S1, S2, S3 and S4. Jumpers S1 & S2 are used to setup the telephone ringing frequency as either 50Hz or 25Hz:-

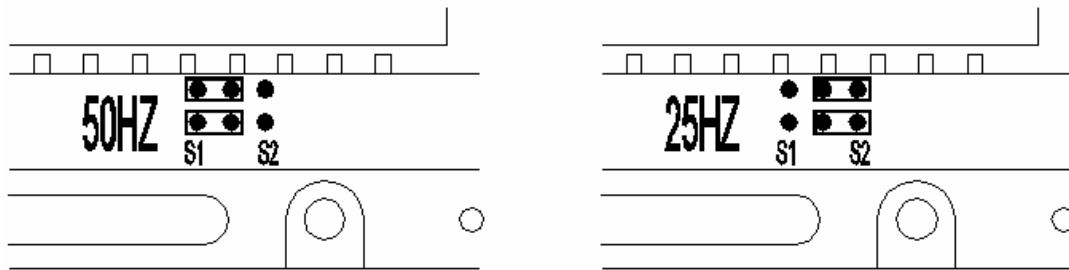

Jumpers S3 & S4 are for setting the speech circuit type to either 2 wire or four wire. A four wire system would be either a 837, 836, 831K, 537 or 536, 2280 amplifier in the door panel and a 2 wire system would be either a 831M or a 835 amplifier in the door panel.

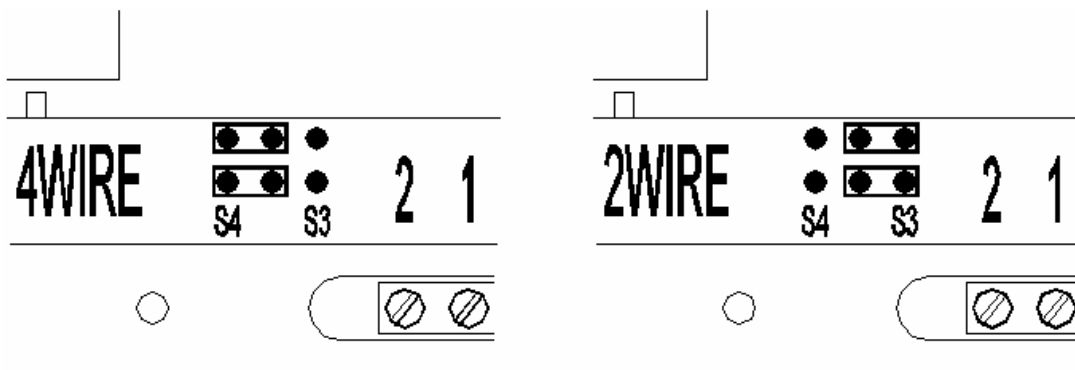

Programming overview

Most of the features of the Art380 can be adjusted using the telephone keypad connected to the output of the Art380. This will need to be a 'Tone dial' telephone capable of producing DTMF tones. After each programming function, the handset should be replaced. Confirmation tones can be heard at the end of each segment of programming to either indicate if the information entered has been accepted and understood or if the information has not been

understood and so is required to be entered again. If during the programming, a mistake is made, simple hang up the telephone and start again.

Tones overview

- Upon lifting the handset you should hear the telephone line tone. (If the system is in PABX mode you will still hear a line tone but this will be a higher frequency to the one normally heard on a telephone line.
- On entering ** to gain access to the functions and programming facility the line tone will change to a higher frequency (Note: When in PABX mode the tone stays the same.
- Upon pressing the first digit of the programming command, the line tone will stop.
- As you type the command digits, you will hear the DTMF tones.
- Upon completion of the command you will hear a double beep to confirm the command was accepted. If you hear a number of fast beeps or an engaged tone, the command has not been accepted and you should replace the handset and start again.
- The fast beeps will also indicate an incorrect access code if this facility has been setup to secure access to the programming menu.

The following table is a quick guide to the programming. This will be followed by a more descriptive guide to the programming:

NOTE: If the access code is enabled this should be entered after the **. For example to reverse the relay when a code of 1234 is setup, enter [1234 10 1].**

Description	Code	Variant X	Default X
Relay reversal (NO or NC)	** 10 X	X = 1 or 0 (1 for a normally closed circuit for use with power to lock releases and 0 for a normally open circuit for power to open releases.	0
Alternate between local call and divert mode.	** 11 X	X = 1 or 0 (1 for divert mode & 0 for local call mode)	0
Dial in facility enable/disable	** 12 X	X = 0 or 1 (1 for enabling the dial in facility and 0 for disabling the dial in facility)	0
Pulse mode	** 13 X	X = 0 or 1 (0 to disable pulse dial facility and 1 to enable)	0
PABX mode	** 14 X	X = 0 or 1 (0 for normal mode and 1 for PABX mode)	0
Hands free mode	** 15 X	X = 0 or 1 (0 for standard speech mode and 1 for hands free speech mode)	0
One way speech mode	** 16 X	X = 0,1 or 2 (0 duplex speech, 1 for transmitting speech only and 2 for receiving speech only).	0
** mode disable	** 17 X	X = 0 or 1 (0 to enable ** reading and 1 to disable)	0
Direct DTMF reading	** 18 X	X = 0 or 1 (0 to disable direct reading and 1 to enable direct reading)	1
AUX 2 direct control	** 19 X	X = 0 or 1 (0 to allow A2 to automatically trigger upon a call and 1 for direct control by	1

		user)	
Access code enable/disable for local use.	** 20 X	X = 0 or 1 (0 to enable the code for local use and 1 to disable the code during local use)	1
Number of rings	** 21 X	X = 0 to 9 (0 = 10 rings, 1 – 9 = number of rings)	6
Door open time	** 22 X	X = 0 to 9 (0 = 1 second, 1 – 9 multiplied by 2. i.e. X = 3, time = 6 seconds. X = 4, time = 8 seconds).	3
Door open key	** 23 X	X = 0, 8 or 9	0
Divert call/dial in time	** 24 X	X = 0 to 9 (X multiplied by 30 seconds = time. i.e. X = 2, time = 60 seconds. X = 4, time = 120 seconds).	2
Dial in number of rings	** 25 X	X = 0 to 9 (0 = 10 rings. 1 to 9 = number of rings before automatically answering)	5
Internal to external speech volume adjust	** 26 X	X = 0 to 9 (0 being the minimum volume and 9 being the maximum volume)	5
External to internal speech volume adjust	** 27 X	X = 0 to 9 (0 being the minimum volume and 9 being the maximum volume)	5
A1 auxiliary output control	** 28 X	X = 0 or 1 (0 for latching trigger and 1 for momentary trigger)	1
A2 auxiliary output control	** 29 X	X = 0 or 1 (0 for latching trigger and 1 for momentary trigger)	1
At home control	** 30 X	X = 0 or 1 (0 to activate at home control and 1 to disable)	1
Access code	** 31 XXXX	X = four digit access code (Must begin with either 1, 2, 3 or 4) (1111 to disable)	No code
Divert phone numbers	** 32 1 n #	n = Telephone number (Example: program the number as 0123 456789 would be ** 32 1 0123456789 # NOTE: Always confirm the number using the # key.	N/A
Revert to default settings	** 33 1111	Resets all setting to default	N/A
Reassurance tone at the door panel	**34 X	X = 0 or 1 (1 to activate reassurance tone and 0 to deactivate)	0
Divert to number after n seconds	** 35 X	X = 0 – 9 (0 to disable the divert and 1 – 9 multiplied by 4 for time. i.e. When X = 3 time will be 12 seconds before automatic divert)	0
Divert mode audio automatically on/off	**36 X	X = 0 or 1 (0 to enable the speech automatically and 1 to manually open the speech by pressing 2 after answering the call.	0

Programming & User functions explained

Initial setup:

Begin by resetting the Art380 to the factory defaults: **** 33 1111**

Note: If you are unable to reset using this process because you have enabled a code but are not sure what it is then follow the following manual reset procedure:

1. Switch off the power to the Art380
2. Short terminals - & SK
3. Switch on the power to the Art380
4. Remove the short between terminals - & SK
5. The Art380 has now been reset to factory default settings.

This method will also switch the Art380 into PABX mode and so to revert the unit back to normal mode, pickup the handset and type **** 14 0**.

Optional call adjustments

The following adjustments can be made to tailor the system to a clients requirements:

Note: [Code] is optional and is only required when a code has been setup. After factory reset the code is disabled and so is not required during programming.

Adjust the number of rings:

The Art380 can be programmed to ring the telephone(s) for as little as 1 ring or for a maximum of 10 rings using one of the following codes:-

Code	Rings	Code	Rings
** [Code] 21 1	1	** [Code] 21 6	6
** [Code] 21 2	2	** [Code] 21 7	7
** [Code] 21 3	3	** [Code] 21 8	8
** [Code] 21 4	4	** [Code] 21 9	9
** [Code] 21 5	5	** [Code] 21 0	10

Adjust the door open time:

The Art380 can be programmed to release the door for as little as 1 second up to a maximum of 18 seconds:-

Code	Seconds	Code	Seconds
** [Code] 22 0	1	** [Code] 22 5	10
** [Code] 22 1	2	** [Code] 22 6	12
** [Code] 22 2	4	** [Code] 22 7	14
** [Code] 22 3	6	** [Code] 22 8	16
** [Code] 22 4	8	** [Code] 22 9	18

Relay reversal: The contacts on the relay for the door release are normally open (NO). This can be changed to a normally closed contact for use with power to lock releases:-

Code	Status	Code	Status
** [Code] 10 1	NC	** [Code] 10 0	NO

Changing the door open key:

The door open key is 0 when factory defaulted but can be changed to either 8 or 9:-

Code	Key	Code	Key
** [Code] 23 0	0	** [Code] 23 8	8
** [Code] 23 9	9		

Setting up the auxiliary outputs

There are two auxiliary outputs available on the Art380 labelled A1 and A2. These outputs are a switched negative (Open collector) and can be used for a number of facilities including activating dry contact relays. The outputs can be set to latch on activation or switch momentarily.

Latching or momentary output:

Code	Output	Code	Output
** [Code] 28 0	A1 Latching	** [Code] 28 1	A1 Momentary
** [Code] 29 0	A2 Latching	** [Code] 29 1	A2 Momentary

Using auxiliary outputs:

- To activate auxiliary 1 (A1) during a call simply press **5**. If the auxiliary output is set to latch then it will be necessary to press **5** again to unlatch the output.
- To activate auxiliary 1 (A1) without a call being in progress simply pick up the handset and press ** [Code] **5**. If the output is set to latch, follow the same procedure to unlatch.
- To activate auxiliary 2 (A2) during a call simply press **6**. If the auxiliary output is set to latch then it will be necessary to press **6** again to unlatch the output.
- To activate auxiliary 2 (A2) without a call being in progress simply pick up the handset and press ** [Code] **6**. If the output is set to latch, follow the same procedure to unlatch.

Additionally, Auxiliary output A2 can be programmed to automatically activate when a call is placed. Please note: If A2 is set to activate automatically it can not also be set to latch as indicated above.

Code	Output	Code	Output
** [Code] 19 0	Automatic	** [Code] 19 1	Manual

Advanced speech setup options

The speech on the Art380 can be setup to work in a number of different ways. This could be simplex, duplex or even hands free. Additional to being able to adjust the speech volume by means of the volume controls on the door panel it is also possible to adjust the volume in both directions electronically.

Changing the speech volume electronically: The volume can be adjusted from 0 – 9. 0 being the lowest volume and 9 being the highest.

Code	Direction of speech
** [Code] 26 (0-9)	Telephone to door panel
** [Code] 27 (0-9)	Door panel to telephone

One way speech mode: Simplex speech mode will allow each direction of speech to be opened independently.

Code	Direction of speech
** [Code] 16 (0)	Both directions
** [Code] 16 (1)	Transmitting to door panel
** [Code] 16 (2)	Receiving from door panel

Hands free speech mode: The speech will automatically adjust to the direction of speech activity.

Code	Hands free
** [Code] 15 (0)	Not activated
** [Code] 15 (1)	Activated

Dial in facility setup

The dial in facility can be used to allow a caller from a telephone line to dial into the Art380 and access the functions available. This could be to open the door or activate an auxiliary output.

Activating / deactivating the dial in facility:

Code	Facility
** [Code] 12 (0)	Disabled (Default)
** [Code] 12 (1)	Enabled

Activate after a number of rings: The Art380 can count the number of rings before it activates and takes hold of the call. This can be set from 1 – 10 rings. (Note: Each BT ring is a double ring and so counts as two rings.)

Code	Rings	Code	Rings
** [Code] 25 (1)	1	** [Code] 25 (6)	6
** [Code] 25 (2)	2	** [Code] 25 (7)	7
** [Code] 25 (3)	3	** [Code] 25 (8)	8
** [Code] 25 (4)	4	** [Code] 25 (9)	9
** [Code] 25 (5)	5	** [Code] 25 (0)	10

Dial in time/Divert time: The dial in time can be set from 30 seconds to 300 seconds. This is the maximum time a call can last for before clearing down and releasing the line.

Code	Seconds	Code	Seconds
** [Code] 24 (1)	30	** [Code] 24 (6)	180
** [Code] 24 (2)	60	** [Code] 24 (7)	210
** [Code] 24 (3)	90	** [Code] 24 (8)	240
** [Code] 24 (4)	120	** [Code] 24 (9)	270
** [Code] 24 (5)	150	** [Code] 24 (0)	300

Divert call setup

The divert facility allow a call to be diverted to another telephone number. When in divert mode it is recommended you use a four digit access code to restrict the functions of the Art380 to authorised callers. Also see box above for divert time which is the time allowed before a call will clear.

To program the divert telephone number: The telephone number can be a maximum of 40 digits in length.

Code	
** [Code] 32 1 number #	First telephone number

To switch between divert mode and normal mode: When in divert mode and a call is placed, the Art380 will ring the telephone number stored without ringing the telephone connected to the output of the Art380.

Code	Divert mode
** [Code] 11 1	Activated
** [Code] 11 0	Deactivated

To setup the system to divert the call automatically after a preset number of seconds: When this mode is enabled, the telephone in the house will ring for the number of seconds programmed and if after this period the call still has not been answered, it will divert to the pre-programmed telephone.

Code	Seconds	Code	Seconds
** [Code] 35 (1)	4	** [Code] 35 (6)	24
** [Code] 35 (2)	8	** [Code] 35 (7)	28
** [Code] 35 (3)	12	** [Code] 35 (8)	32
** [Code] 35 (4)	16	** [Code] 35 (9)	36
** [Code] 35 (5)	20	** [Code] 35 (0)	Disabled

Speech automatically open when answering a divert call:

When set to 1 it will be necessary to press 2 after answering a call that has been diverted to your phone. This feature disables the door panel amplifier until 2 is pressed so that no dialling sounds are heard and the caller is not aware of the call being diverted.

Code	Automatic speech enable
** [Code] 36 1	Must press 2 to open speech
** [Code] 36 0	Speech opens automatically

Example 1 -A call diverted to a mobile phone when **36 1 is set:-

1. The mobile phone will ring and the caller display will show that it is from the telephone number attached to the Art380.
2. Answer the call. No sound will be heard.
3. Press 2. The speech will open to the door panel.

Example 2 – A call diverted to a mobile phone when **36 0 is set:-

1. The mobile phone will ring and this will be heard from the door panel as well.
2. Answer the call. Speech will open automatically.

Access code setup

The access code is used to restrict access to the programming menu and commands. It can be disabled, setup for both local calls and diverted calls or setup for just diverted calls.

Edit or delete code:

Code	
** [Code] 31 XXXX	Change the code to XXXX
** [Code] 31 1111	Delete the code

Enable/Disable access code for local calls:

Code	Enabled or disabled
** [Code] 20 0	Enabled
** [Code] 20 1	Disabled (Default)

Specialised setup

The following options can be adjusted for specialised situations. For standard installations these settings will not normally need to be adjusted.

Pulse mode: The pulse mode facility can be used with old pulse style telephones which can not generate DTMF tones.

Code	Pulse mode
** [Code] 13 0	Disabled (Default)
** [Code] 13 1	Activated

PABX mode: PABX mode can be used on systems which do not have a telephone line or have a telephone line but needs to be isolated from it. When this is activated it will be necessary to press 0 to select the telephone line before dialling a number.

Code	PABX Mode
** [Code] 14 0	Disabled (Default)
** [Code] 14 1	Activated

Note: It is also possible to put the Art380 into PABX mode by following these steps:

1. Switch the mains off to the Art380
2. Short terminals - & SK.
3. Turn on the mains to the Art380
4. Remove the short from terminals - & SK (After a short click)

Note: This procedure also defaults the Art380.

Disable ** Mode: An alternative to using the ** to enter programming is RECALL RECALL or FLASH FLASH.

Code	**
** [Code] 17 0	Enabled (Default)
** [Code] 17 1	Disabled

Direct DTMF reading: Allows the tones to be read during a call by the Art380 without first pressing **

Code	DTMF Reading
** [Code] 18 0	Disabled
** [Code] 18 1	Enabled (Default)

At home control: This feature allows the 'divert call' to be automatically switched off when active by simply picking up one of the handsets on the output of the Art380 and replacing it.

Code	At home control
** [Code] 30 0	Enabled
** [Code] 30 1	Disabled (Default)

User commands

The following commands can be used to activate functions of the Art380. Note: If the code facility is active, this will be required before the command will work.

Command	Function
Either 0 , 8 or 9 depending on programming	Open the door during a call.
1	During dial in mode, pressing 1 will enable the divert facility.
2	Press 2 during dial in mode to open the speech to the door panel. Also press 2 after answering a call in divert mode to open the speech to the door panel (When this mode is active i.e. **361)
5	Activate auxiliary 1
6	Activate auxiliary 2 (Only when aux 2 is set to direct control.
0	Connect to telephone line (PABX mode only)
**7	Open speech to door without first being called and switch between calls.
7	During divert mode it will end the call and switch off the door panel. (Recommended way to end a diverted call)
#	Clear to start again if a mistake is made when typing code in the divert mode.

User command examples: (Note: The examples are for default settings)

- **To open the speech to the door panel without first being called** ****7**
- **To divert to a door call while talking on the telephone** ****7**
(Note: To go back to the telephone call simply hang up and then pick up again)
- **To divert to a telephone call while talking to the door** ****7**
(Note: To go back to the door call, simply hang up and then pick up again)
- **To open the door without first being called** ****0**
- **To open the door during a call** **0**
- **To put the system in divert mode** ****111**
- **To take the system back out of divert mode** ****110**
- **To activate auxiliary 1 without first being called** ****5**
- **To activate auxiliary 2 without first being called** ****6**
- **To activate auxiliary 1 during a call** **5**
- **To activate auxiliary 2 during a call** **6**
- **To activate the speech when dialling in** **2**
- **To activate the speech in divert mode (When setting ****361** is set)** **2**

APPROVAL

The equipment has been approved in accordance with Council Decision 98/482/EC for pan-European single terminal connection to the public switch telephone network (PSTN). However, due to differences between the individual PSTNs provided in different countries, the approval does not, of itself, give an unconditional assurance of successful operation on every PSTN network termination point. In the event of problems, you should contact your equipment supplier in the first instant.

Your Art.380 telephone interface is fully approved to be connected to the following circuits :-

Public Switched Telephone Network (PSTN) - Non DDI
Private Branch Exchange (PBX)



If the unit is to be used on any other network that is not listed above, you must first contact the vendor.

The Art380 telephone interface complies fully with the requirements of **TBR21** in all modes of operation.

Troubleshooting guide

In the event of problems occurring during the installation of the Art380 telephone interface please check this troubleshooting guide before calling the Videx technical help on 0191 224 3174.

Telephone does not ring but if it is picked up during a call there is speech to the door :-

Option 1 : The REN value has been exceeded. Do the test again with only one telephone connected. If it works then the REN value has been exceeded and the number of telephone on the system must be reduced.

Option 2 : A master socket has not been fitted to the output of the ART380. The telephone will not ring if this is a secondary socket or a faulty master socket. (The master socket has a large capacitor inside.)

Option 3 : The correct voltage is not coming from the Art380. (An AC voltage of approx. 30 volts should be present across T1 & T2 during the ringing cycle).

The speech lines do not open when ** 7 is pressed :-

Option 1 : The ** facility has been disabled on the Art380. To enable this, pick up the handset and press RECALL RECALL 17 0. Hang up the telephone. The Art380 is now programmed to accept **.

Option 2 : The telephone you are using does not support DTMF dialling.

The door does not open when '0', '8' or '9' is pressed :-

Option 1 : The telephone you are using does not support DTMF dialling.

Option 2 : The lock is not wired correctly to the Art380. The Art380 has a dry contact relay output across C & NO. These two terminals short together when the door open is activated.

The door opens when it should close and closes when it should open:-

Option 1 : The relay has been programmed to be either normally closed when it should be normally open or normally open when it should be normally closed. Reprogram the Art380 relay reverse correctly.

The Art380 does not activate at all when called :-

Option 1 : Check the mains supply is connected to the Art380 and is correct.

Option 2 : Check the mains fuse inside the Art380.

Option 3 : Use a meter to check it is getting a signal across terminals 3 and 6 when a call is placed. The voltage across these two terminals should be 12V AC or DC. (Without this voltage the Art380 will not trigger).

There is no dial tone when the handset is lifted :-

Option 1 : Check there is a line tone before the Art380 by moving the telephone to the line input.

Option 2 : Check the line cord is connected to the incoming master socket and that the cord is not faulty.

Option 3 : Check the new master socket fitted across terminals T1 & T2 of the Art380N has the wires connected to terminals 2 and 5.

Option 4 : Check the telephone being used is working correctly.

No speech from the door panel to the telephone :-

Option 1 : Check terminal 2 from the door panel to the Art380. When there are no calls on the system a voltage of 8V DC should be present across 2 and negative.

Option 2 : If possible, test the door panel speech with a Videx telephone.

No speech from the telephone to the door panel :-

Option 1 : Check terminal 1 from the door panel to the Art380. When there are no calls on the system a voltage of 8V DC should be present across 1 and negative.

Option 2 : If possible, test the door panel speech with a Videx telephone.

The speech is too loud and feed back occurs.

Option 1 : Try adjusting the volume at the door panel. (POTS on rear of amp module)

Option 2 : Try adjusting the internal/external volume using function codes 26 & 27 of the programming menu.

Option 3 : Check the unit is not in handset free mode.

SPECIFICATION:

Supply voltage	230V AC
Max number of telephone	2
Enclosure material	ABS plastic
Dimensions	157.5mm(L) x 105mm(W) x 65mm(H) [Standard 9 module DIN box]
+12V out	100mA Max
Relay contacts	2A DC, 2A AC resistive 1A AC inductive - 24VDC 120V AC

If help is required for installing or operating this unit, please contact our technical department on:
+39 734 631669 (all countries) or 0191-224-3174 (UK Only)

EXAMPLE INSTALLATIONS USING ART.380

This is a new primary socket supplied with the Art.380 and is where the telephone plugs into.

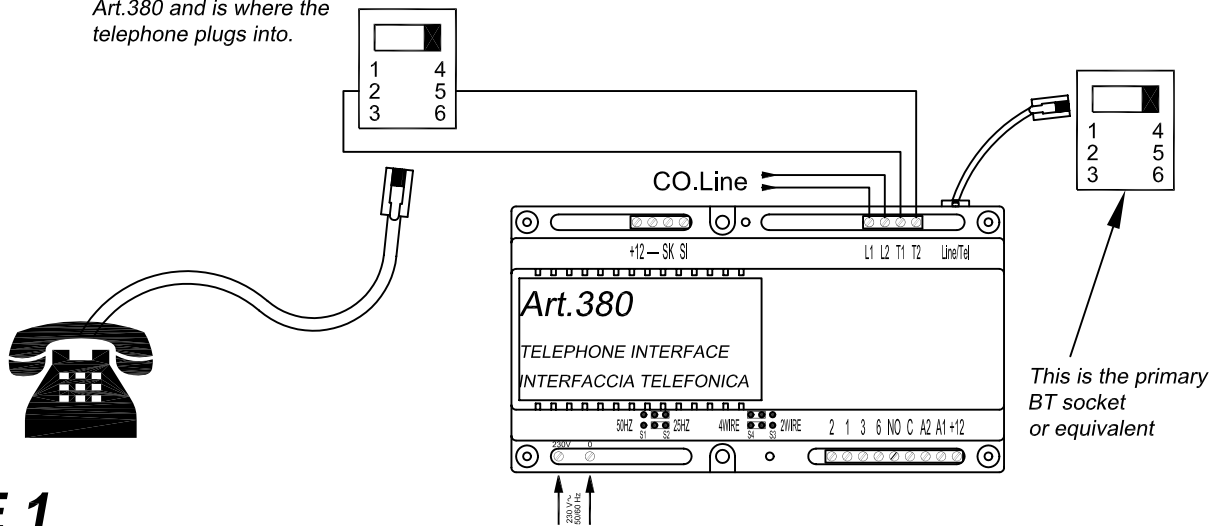

EXAMPLE 1

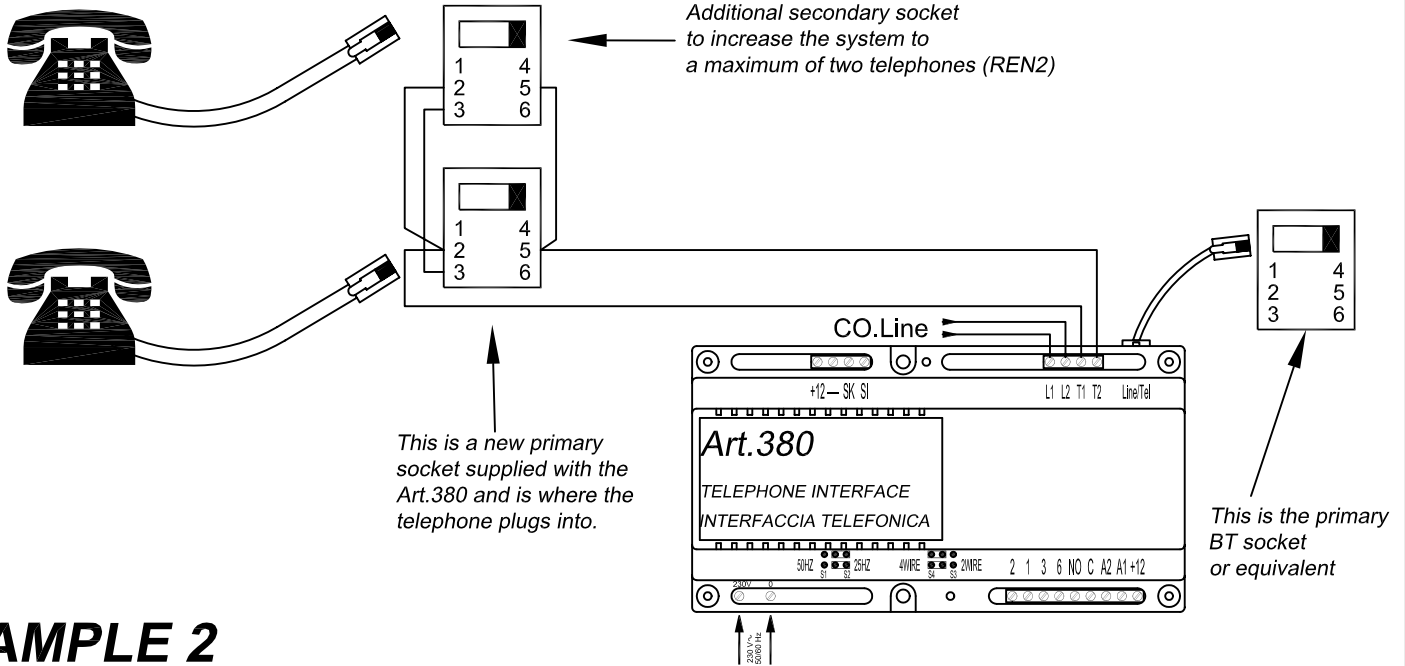

EXAMPLE 2

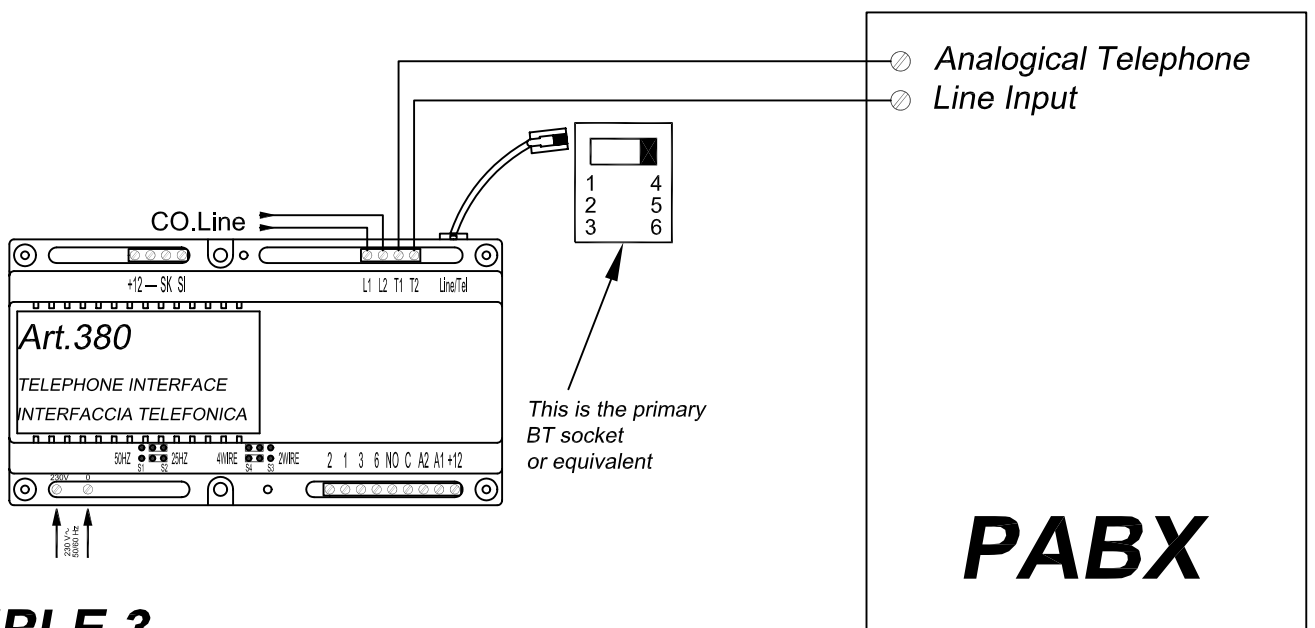

EXAMPLE 3



VIDEX ELECTRONICS S.p.A.

DENOMINAZIONE: Art.380 Connection Examples

COD.FILE: APPART380

DATA: 26/07/2004

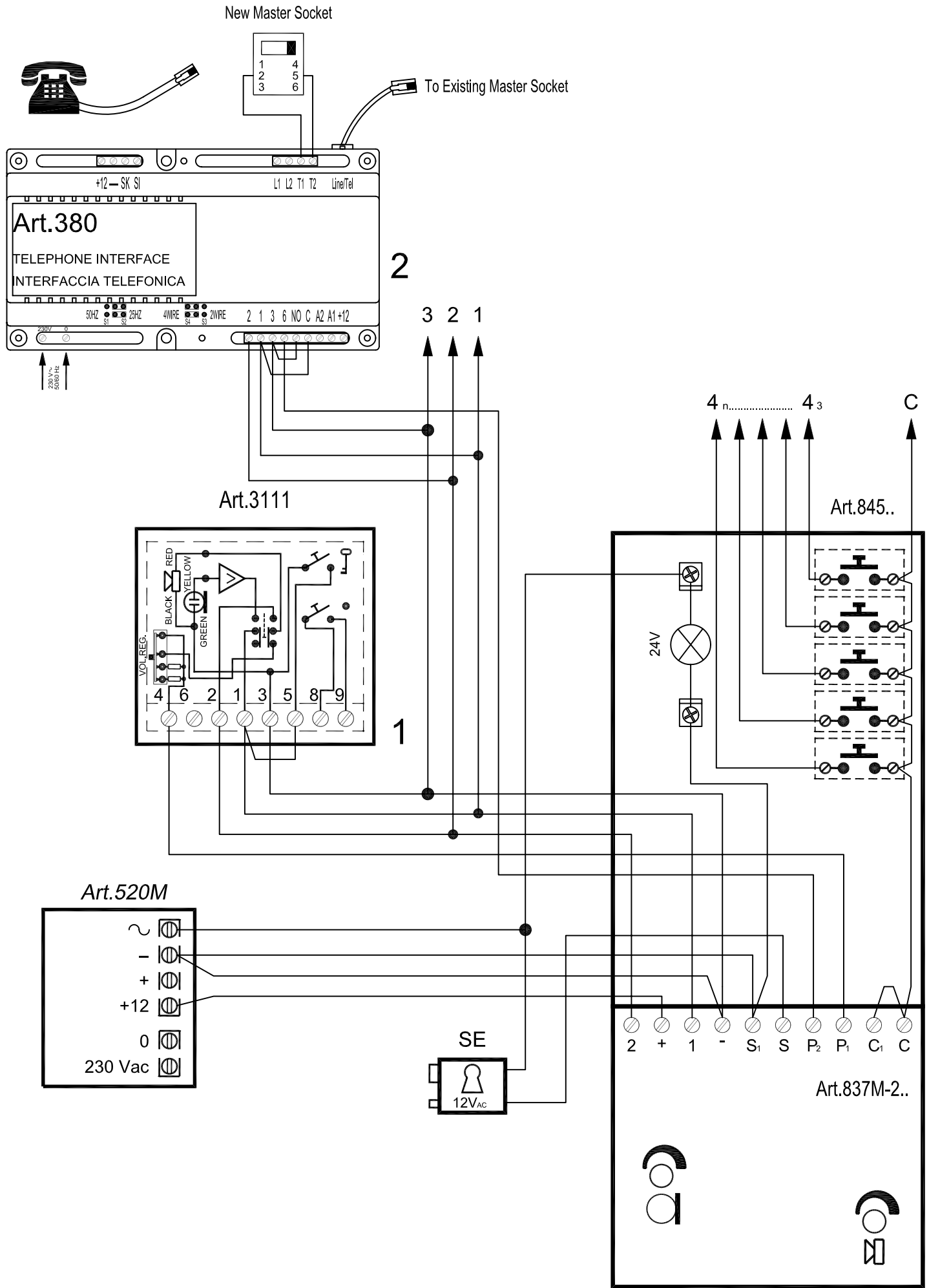

VIDEX ELECTRONICS S.p.A.

DENOMINAZIONE: 3000 Series One Entrance Audio System plus Art.380

COD.FILE: 380002UK

DATA: 27/07/2004

Art.924

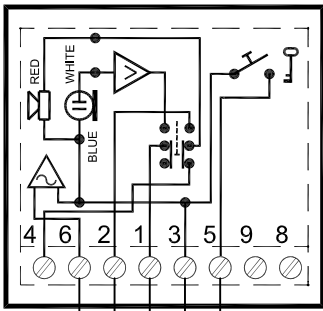

3 2 1 5



NEW MASTER SOCKET

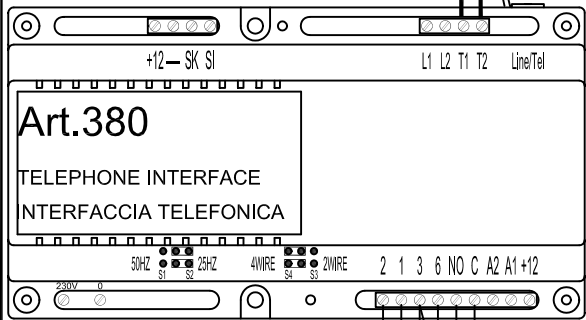
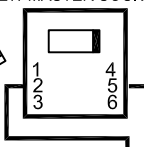

230V
50/60 Hz

Existing Master Socket

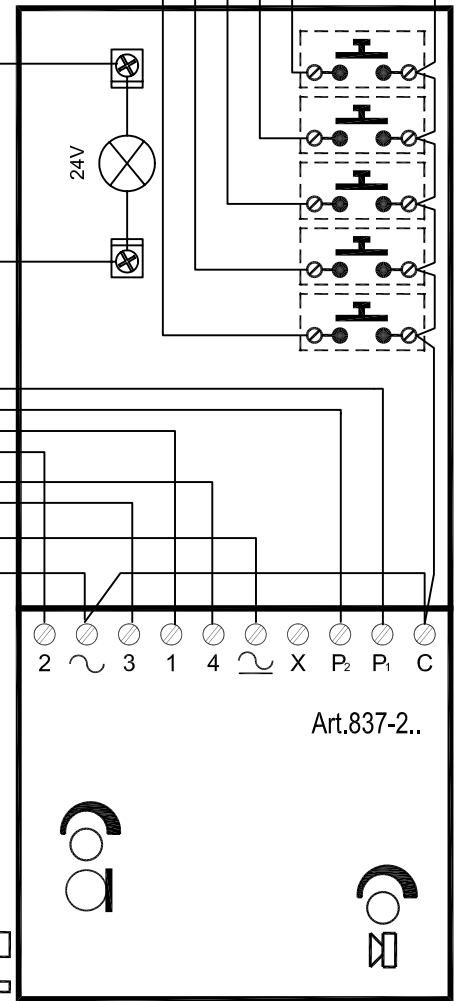
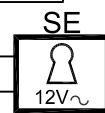
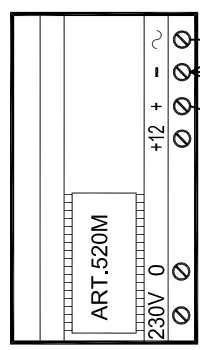

VIDEX ELECTRONICS S.p.A.

DENOMINAZIONE: 900 Series One Entrance Audio System plus Art.380

COD.FILE: 380001

DATA: 27/07/2004

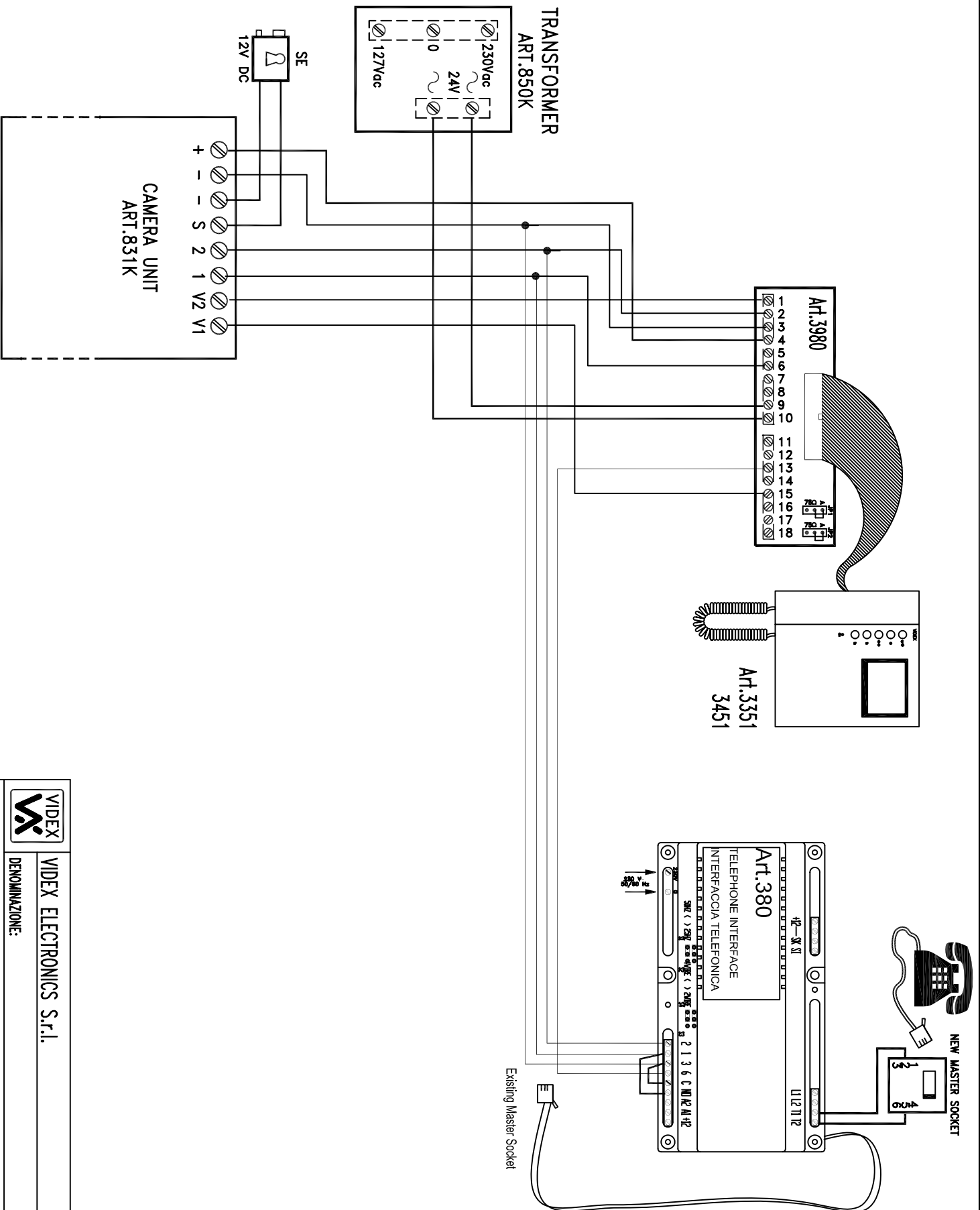

VIDEX ELECTRONICS S.r.l.

DENOMINAZIONE:

VIDEOKIT VK6N + Art380

DATA: 03/08/04

VK6N00007d