

IT  
FOGLIO  
TECNICO

EN  
TECHNICAL  
SHEET

FR  
FEUILLE  
TECHNIQUE

## MT KIT 12

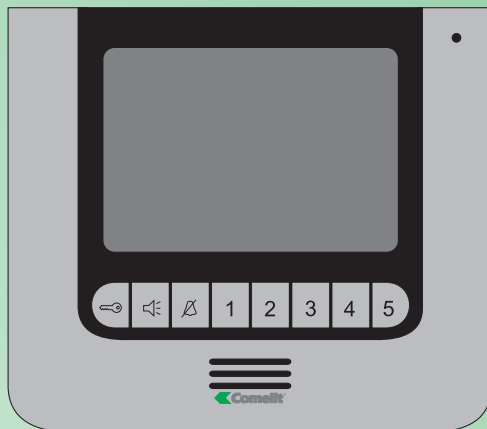

# iPower

## Manuale tecnico installatore iPower kit Technical installation manual - iPower kit Manuel technique d'installation iPower kit

Assistenza tecnica Italia 0346/750090  
Commerciale Italia 0346/750091

Technical service abroad (+39) 0346750092  
Export department (+39) 0346750093



Comelit Group S.p.A. - Via Don Arrigoni 5 - 24020 Rovetta S. Lorenzo BG Italy - tel. (+39) 0346 750 011 - fax (+39) 0346 71436  
www.comelit.eu www.simplehome.eu info@comelit.it commerciale.italia@comelit.it export.department@comelit.it

**IT** Avvertenze

- Effettuare l'installazione seguendo scrupolosamente le istruzioni fornite dal costruttore ed in conformità alle norme vigenti.
- Tutti gli apparecchi devono essere destinati esclusivamente all'uso per cui sono stati concepiti. **Comelit Group S.p.A.** declina ogni responsabilità per un utilizzo improprio degli apparecchi, per modifiche effettuate da altri a qualunque titolo e scopo, per l'uso di accessori e materiali non originali.
- Tutti i prodotti sono conformi alle prescrizioni delle direttive 2006/95/CE (che sostituisce la direttiva 73/23/CEE e successivi emendamenti) e ciò è attestato dalla presenza della marcatura **CE** sugli stessi.

**EN** Warning

- Install the equipment by carefully following the instructions given by the manufacturer and in compliance with the legislation in force.
- All the equipment must only be used for the purpose it was built for. **Comelit Group S.p.A.** declines any responsibility for improper use of the apparatus, for modifications made by others under any title or scope, and for the use of accessories and materials which are not the original ones.
- All the products comply with the requirements of the 2006/95/CE directives (which replace the 73/23/CEE directives and the successive amendments). This is proved by the **CE** mark on the products.

**FR** Avertissement

- Effectuer l'installation en suivant scrupuleusement les instructions fournies par le constructeur et conformément aux normes en vigueur.
- Tous les appareils doivent être strictement destinés à l'emploi pour lequel ils ont été conçus. **Comelit Group S.p.A.** décline toute responsabilité en cas de mauvais usage des appareils, pour des modifications effectuées par d'autres personnes pour n'importe quelle raison et pour l'utilisation d'accessoires non fournis par nous.
- Tous les produits sont conformes aux exigences des directives 2006/95/CE (qui remplacent les directives 73/23/CEE et amendements successifs). Cette conformité est signalée par le symbole **CE** figurant sur les produits.

## SOMMARIO

<b>1</b>	Montaggio telaio posto esterno	pag. 6
<b>2</b>	Cablaggio alimentatore Art. 1397 verso il posto esterno	pag. 7
<b>3A</b>	Serratura in AC (Relé 1)	pag. 8
<b>3B</b>	Serratura in DC (Relé 1)	pag. 9
<b>4</b>	Comando locale temporizzato serratura (Relé 1)	pag. 10
<b>5</b>	Montaggio e orientamento modulo telecamera	pag. 11
<b>6</b>	Tabella impostazioni Dip switch posto esterno	pag. 12
<b>7A</b>	Kit monofamiliare: cablaggio monofase ponte Art. 1398	pag. 13
<b>7B</b>	Kit bifamiliare: cablaggio monofase ponti Art. 1398	pag. 14
<b>7C</b>	Kit bifamiliare con contatore parti comuni: cablaggio monofase ponti Art. 1398	pag. 15
<b>8</b>	Distanze di collegamento	pag. 16
<b>9</b>	Accensione alimentazione generale	pag. 18
<b>10A</b>	Kit monofamiliare: corrispondenza staffa / pulsante di chiamata	pag. 18
<b>10B</b>	Kit bifamiliare: corrispondenza staffa / pulsante di chiamata e alimentatore monitor / ponte Art. 1398	pag. 19
<b>11</b>	Montaggio monitor	pag. 20
<b>12</b>	Segnalazione anomalie e possibili soluzioni	pag. 21
<b>13</b>	Utilizzo relé del modulo numero civico (Relé 2)	pag. 22
<b>14</b>	Installazione monitor supplementari secondari (MAX 14)	pag. 23
<b>15</b>	Abilitare e disabilitare il menu installatore	pag. 25
<b>16</b>	Impostazione lingua menu	pag. 26
<b>17</b>	Accedere al menu installatore	pag. 26
<b>18</b>	Descrizione menu installatore	pag. 26
<b>19</b>	Descrizione icone abbinate ai pulsanti	pag. 26
<b>20</b>	Configurazione password modem	pag. 27
<b>21</b>	Segnalazione anomalie e possibili soluzioni	pag. 28
<b>22</b>	Configurazione pulsanti	pag. 28
<b>23</b>	Attivazione ripetizione suoneria	pag. 31
<b>24</b>	Attivazione risposta automatica	pag. 31
<b>25</b>	Visualizza informazioni	pag. 32
<b>26</b>	Configurazione tempi di chiamata	pag. 32
<b>27</b>	Reset configurazione	pag. 33
<b>28</b>	Menu imposta tipo di rete	pag. 33
	Schema PWK/01A: Cablaggio kit monofamiliare Art. 8591	pag. 50
	Schema PWK/05: Cablaggio kit monofamiliare trifase Art. 8591	pag. 51
	Schema PWK/02A: Cablaggio kit bifamiliare Art. 8592	pag. 52
	Schema PWK/06: Cablaggio kit bifamiliare trifase Art. 8592	pag. 53
	Schema PWK/02B: Cablaggio kit bifamiliare Art. 8592 con contatore parti comuni	pag. 54
	Schema PWK/01B: Cablaggio kit monofamiliare con alimentatore supplementare per posto esterno	pag. 55
	Schema PWK/03: Cablaggio kit monofamiliare con 2 posti esterni	pag. 56
	Schema PWK/04: Cablaggio kit bifamiliare con 2 posti esterni	pag. 57
	Variante PW/AAA: collegamento relé del modulo numero civico (relé 2)	pag. 58
	Variante PW/AAB: collegamento relé temporizzato	pag. 58
	Variante PW/AAC: contatto segnalazione porta aperta	pag. 59
	Variante per utilizzo rete RC per filtro serratura sui contatti del relé 1 o relé 2	pag. 59

## CONTENTS

<b>1</b>	Installing the external unit frame	Page 6
<b>2</b>	Wiring between power supply Art. 1397 and the external unit	Page 7
<b>3A</b>	AC door-release (Relay 1)	Page 8
<b>3B</b>	DC door-release (Relay 1)	Page 9
<b>4</b>	Timed local door-release command (Relay 1) (RTE)	Page 10
<b>5</b>	Installing and adjusting the direction of the camera	Page 11
<b>6</b>	Table of external unit Dip switch settings	Page 12
<b>7A</b>	Single-residence kit: Single-phase wiring for bridge Art. 1398	Page 13
<b>7B</b>	Two-residence kit: Single-phase wiring for bridges Art. 1398	Page 14
<b>7C</b>	Two-residence kit with shared parts meter: Single-phase wiring for bridges Art. 1398	Page 15
<b>8</b>	Connection distances	Page 16
<b>9</b>	Switching on the main power supply	Page 18
<b>10A</b>	Single-residence kit: bracket / call pushbutton alignment	Page 18
<b>10A</b>	Two-residence kit: bracket / call pushbutton and monitor power supply / bridge Art. 1398 alignment	Page 19
<b>11</b>	Installing the monitor	Page 20
<b>12</b>	Fault indication and troubleshooting	Page 21
<b>13</b>	Using the house number module relay (Relay 2)	Page 22
<b>14</b>	Installing additional secondary monitors (MAX 14)	Page 23
<b>15</b>	Enabling and disabling the installer menu	Page 25
<b>16</b>	Setting the menu language	Page 34
<b>17</b>	Entering the installer menu	Page 34
<b>18</b>	Description of the installer menu	Page 34
<b>19</b>	Description of the icons corresponding to the pushbuttons	Page 34
<b>20</b>	Setting the modem password	Page 35
<b>21</b>	Fault indication and troubleshooting	Page 36
<b>22</b>	Programming the pushbuttons	Page 36
<b>23</b>	Activating ringtone repetition	Page 39
<b>24</b>	Activating the automatic response	Page 39
<b>25</b>	Displaying information	Page 40
<b>26</b>	Programming call times	Page 40
<b>27</b>	Reset configuration	Page 41
<b>28</b>	Select type of network menu	Page 41
	Diagram PWK/01A: Wiring for single-residence kit Art. 8591	Page 50
	Diagram PWK/05: Wiring for three-phase single-residence kit Art. 8591	Page 51
	Diagram PWK/02A: Wiring for two-residence kit Art. 8592	Page 52
	Diagram PWK/06: Wiring for three-phase two-residence kit Art. 8592	Page 53
	Diagram PWK/02B: Wiring for two-residence kit Art. 8592 with shared parts meter	Page 54
	Diagram PWK/01B: Wiring for single-residence kit with additional external unit power supply	Page 55
	Diagram PWK/03: Wiring for single-residence kit with 2 external units	Page 56
	Diagram PWK/04: Wiring for two-residence kit with 2 external units	Page 57
	PW/AAA variant: house number module relay connection (relay 2)	Page 58
	PW/AAB variant: timed relay connection	Page 58
	PW/AAC variant: door open indication contact	Page 59
	Variant using RC network for door-release filter on relay 1 or relay 2 contacts	Page 59

## SOMMAIRE

<b>1</b>	Montage châssis plaque de rue	page. 6
<b>2</b>	Câblage alimentateur Art. 1397 vers la plaque de rue	page. 7
<b>3A</b>	Gâche en C.A. (relais 1)	page. 8
<b>3B</b>	Gâche en C.C. (relais 1)	page. 9
<b>4</b>	Commande locale temporisée gâche (relais 1)	page. 10
<b>5</b>	Montage et orientation module caméra	page. 11
<b>6</b>	Tableau réglages Dip switches plaque de rue	page. 12
<b>7A</b>	Kit un appartement : câblage monophasé pont Art. 1398	page. 13
<b>7B</b>	Kit deux appartements : câblage monophasé ponts Art. 1398	page. 14
<b>7C</b>	Kit deux appartements avec compteur parties communes : câblage monophasé ponts Art. 1398	page. 15
<b>8</b>	Distances de connexion	page. 16
<b>9</b>	Allumage alimentation générale	page. 18
<b>10A</b>	Kit un appartement : correspondance bride / touche d'appel	page. 18
<b>10B</b>	Kit deux appartements : correspondance bride / touche d'appel et alimentateur moniteur / pont Art. 1398	page. 19
<b>11</b>	Montage moniteur	page. 20
<b>12</b>	Signalisation anomalies et solutions possibles	page. 21
<b>13</b>	Utilisation relais du module numéro de rue	page. 22
<b>14</b>	Installation moniteurs supplémentaires secondaires	page. 23
<b>15</b>	Valider et invalider le menu d'installation	page. 25
<b>16</b>	Réglage langue menu	page. 42
<b>17</b>	Accéder au menu d'installation	page. 42
<b>18</b>	Description menu d'installation	page. 42
<b>19</b>	Description icônes associées aux touches	page. 42
<b>20</b>	Configuration mot de passe modem	page. 43
<b>21</b>	Signalisation anomalies et solutions possibles	page. 44
<b>22</b>	Configuration touches	page. 44
<b>23</b>	Activation répétition sonnerie	page. 47
<b>24</b>	Activation réponse automatique	page. 47
<b>25</b>	Visualiser informations	page. 48
<b>26</b>	Configuration temps d'appel	page. 48
<b>27</b>	Reset configuration	page. 49
<b>28</b>	Menu programmation type de réseau	page. 49
	Schéma PWK/01A : Câblage kit un appartement Art. 8591	page. 50
	Schéma PWK/05 : Câblage kit un appartement triphasé Art. 8591	page. 51
	Schéma PWK/02A : Câblage kit deux appartements Art. 8592	page. 52
	Schéma PWK/06 : Câblage kit deux appartements triphasé Art. 8592	page. 53
	Schéma PWK/02B : Câblage kit deux appartements Art. 8592 avec compteur pour parties communes	page. 54
	Schéma PWK/01B : Câblage kit un appartement avec alimentateur supplémentaire pour plaque de rue	page. 55
	Schéma PWK/03 : Câblage kit un appartement avec 2 plaques de rue	page. 56
	Schéma PWK/04 : Câblage kit deux appartements avec 2 plaques de rue	page. 57
	Variante PW/AAA : connexion relais du module numéro de rue (relais 2)	page. 58
	Variante PW/AAB : connexion relais temporisé	page. 58
	Variante PW/AAC : contact signalisation porte ouverte	page. 59
	Variante pour emploi réseau RC pour filtre gâche sur contacts du relais 1 ou relais 2	page. 59

- (IT) Montaggio telaio posto esterno.
- (EN) Installing the external unit frame.
- (FR) Montage châssis plaque de rue.

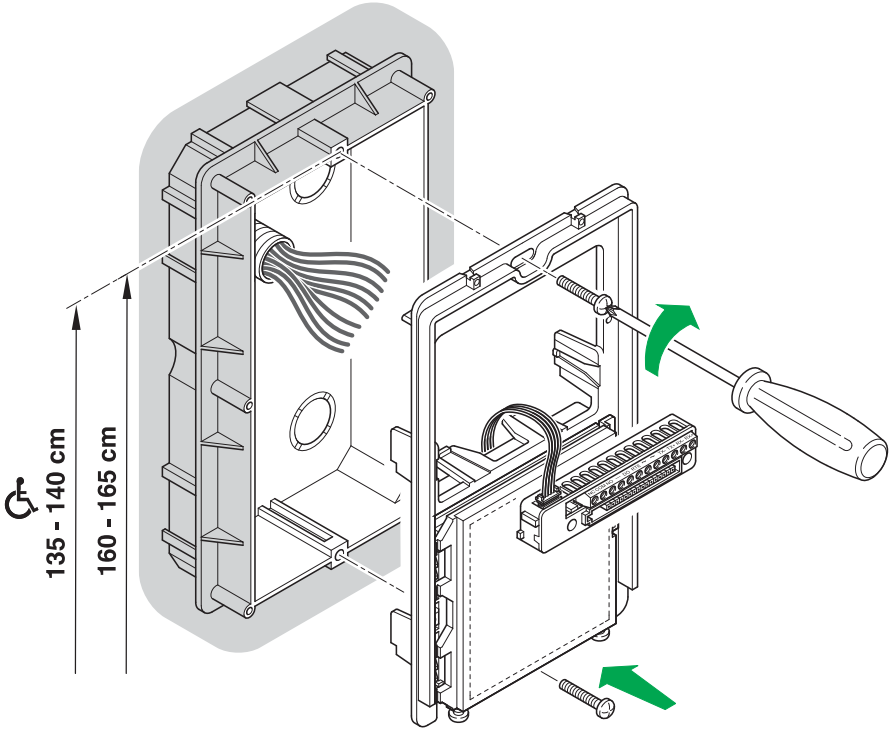

- IT** Cablaggio alimentatore Art. 1397 verso il posto esterno.
- EN** Wiring between power supply Art. 1397 and the external unit.
- FR** Câblage alimentateur Art. 1397 vers la plaque de rue.

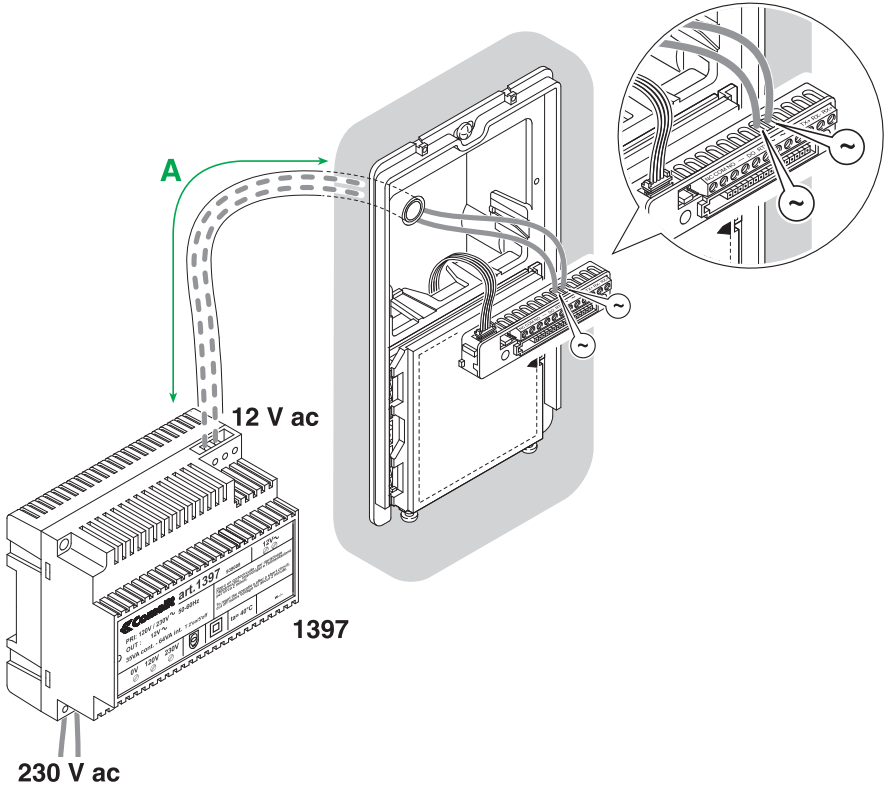

		A Max
0,28 mm <sup>2</sup> (Ø 0,6 mm - Ø 6/10 AWG 23)		
0,2 mm <sup>2</sup> (Ø 0,5 mm AWG 24)		
0,5 mm <sup>2</sup> (Ø 0,8 mm AWG 20)		10 m
0,5 mm <sup>2</sup> (Ø 0,8 mm AWG 20)		10 m
1 mm <sup>2</sup> (Ø 1,2 mm AWG 17)		25 m
1 mm <sup>2</sup> (Ø 1,2 mm AWG 17)		25 m
1 mm <sup>2</sup> (Ø 1,2 mm AWG 17)		25 m
1,5 mm <sup>2</sup> (Ø 1,4 mm AWG 15)		40 m
2,5 mm <sup>2</sup> (Ø 1,8 mm AWG 13)		60 m

- IT Serratura in AC (Relé 1).
- EN AC door-release (Relay 1).
- FR Gâche en C.A. (Relais 1).

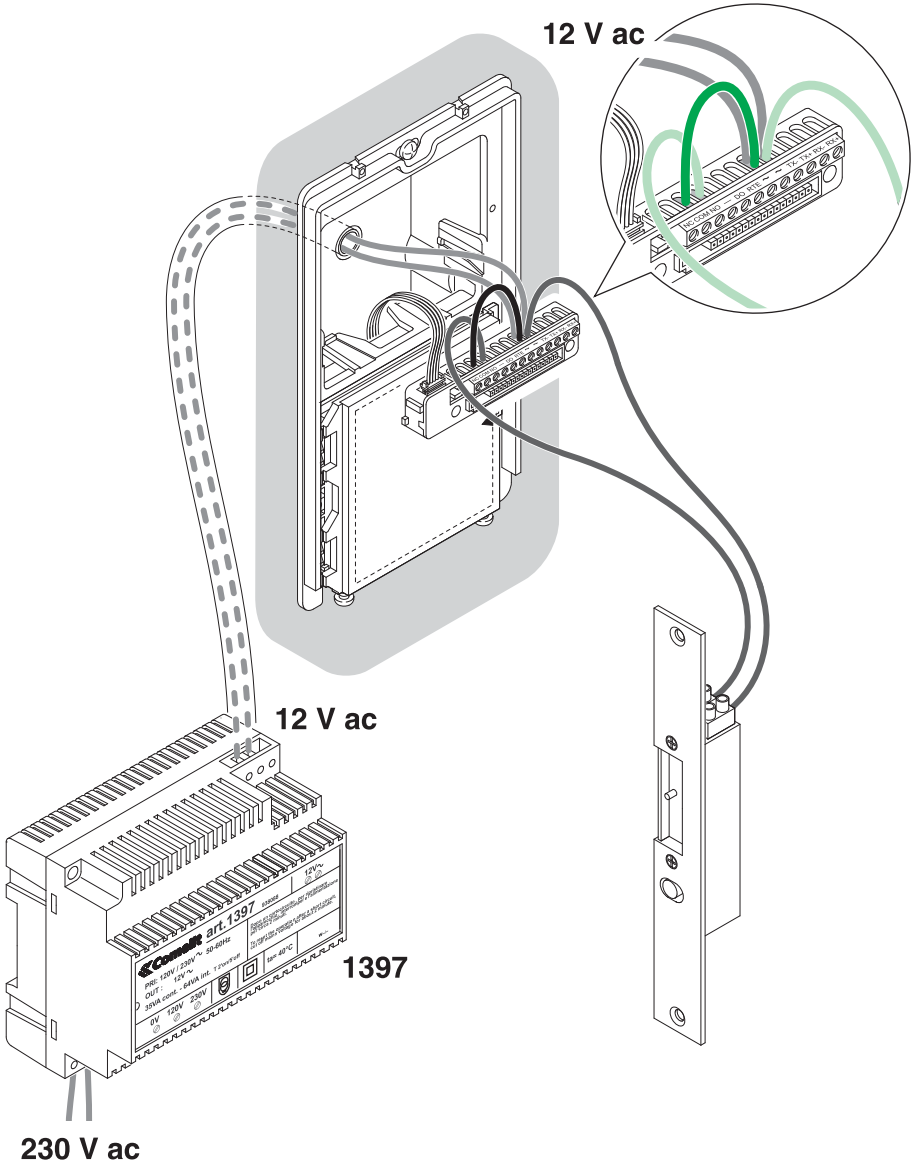



- IT Serratura in DC (Relé 1).
- EN DC door-release (Relay 1).
- FR Gâche en C.C. (Relais 1).

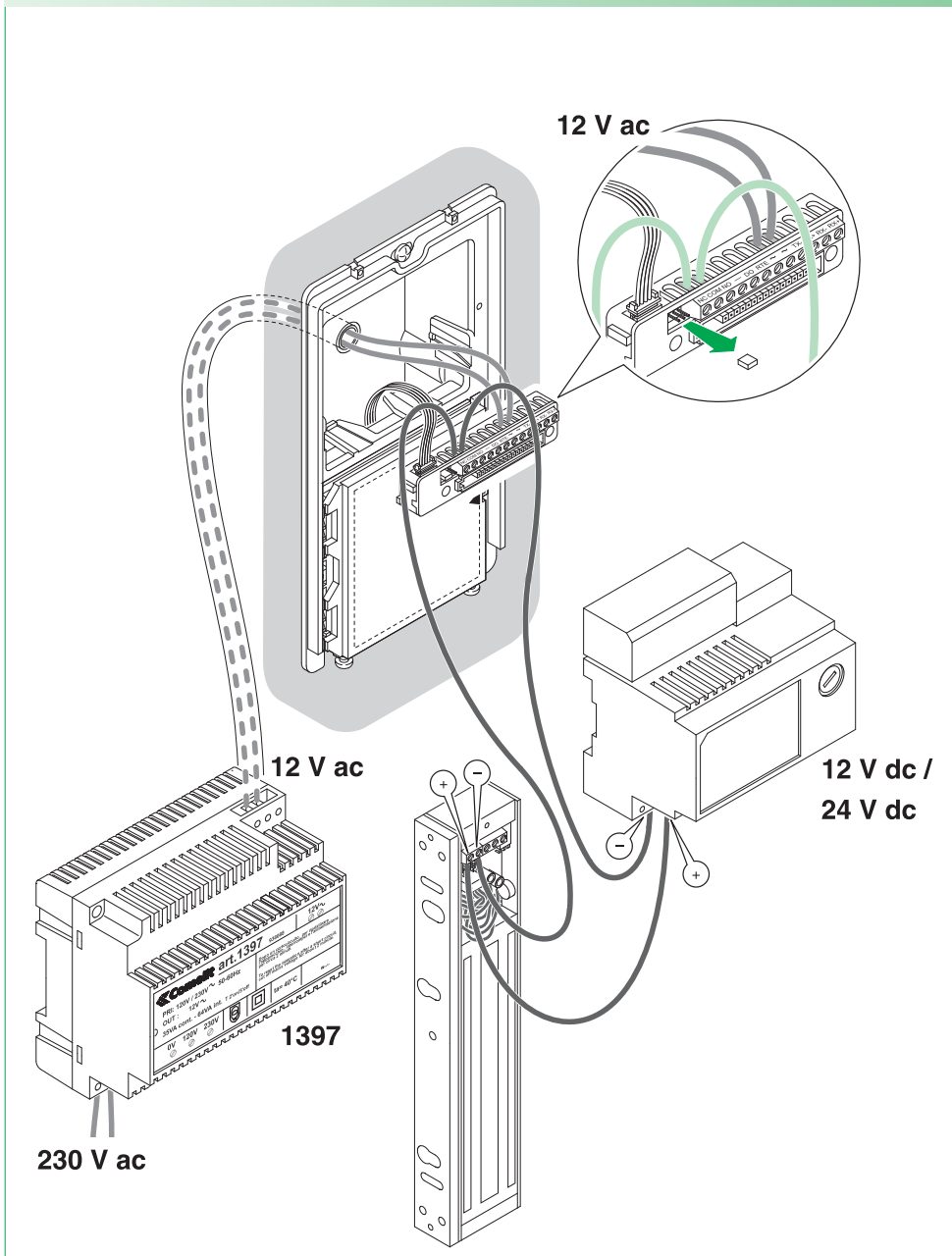

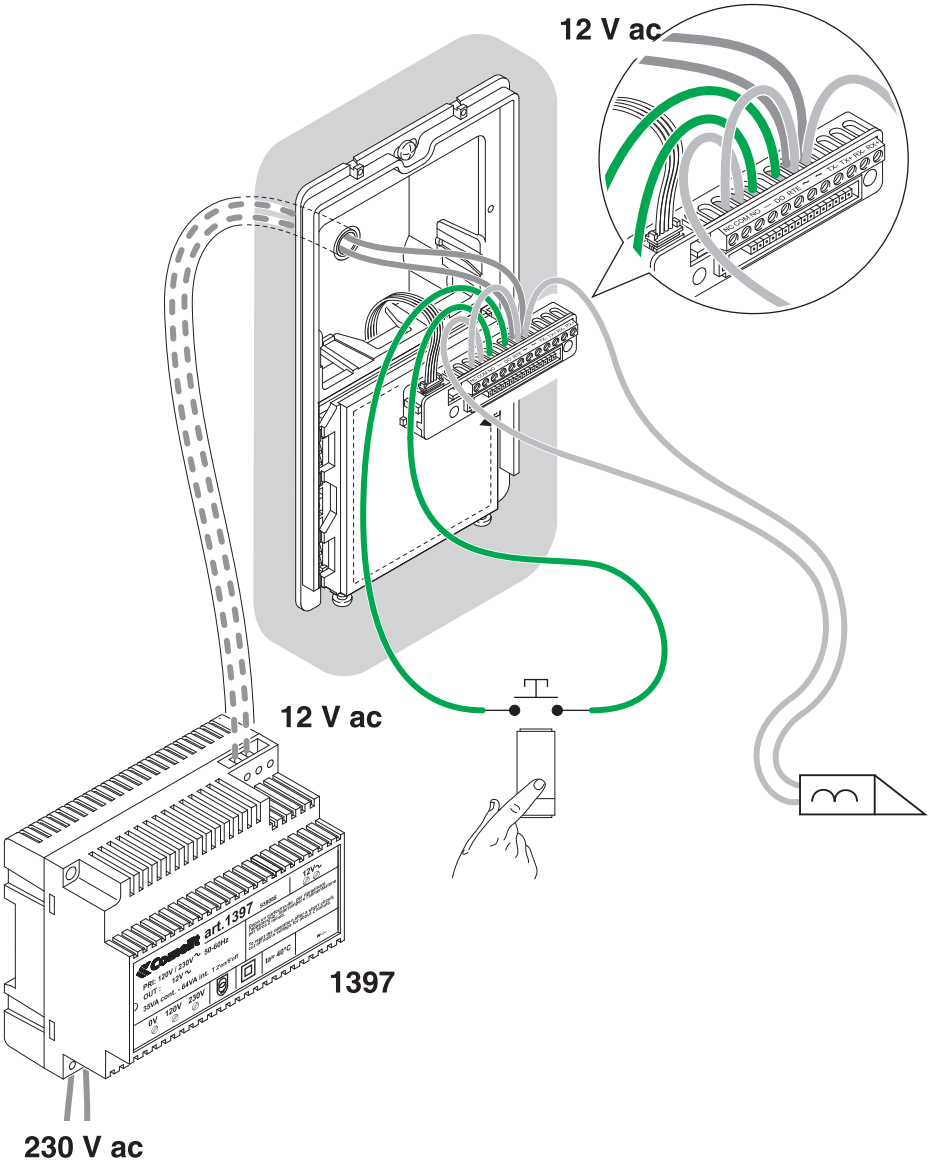

- IT Comando locale temporizzato serratura (Relé 1).
- EN Timed local door-release command (Relay 1) (Request to exit).
- FR Commande locale temporisée gâche (Relais 1).

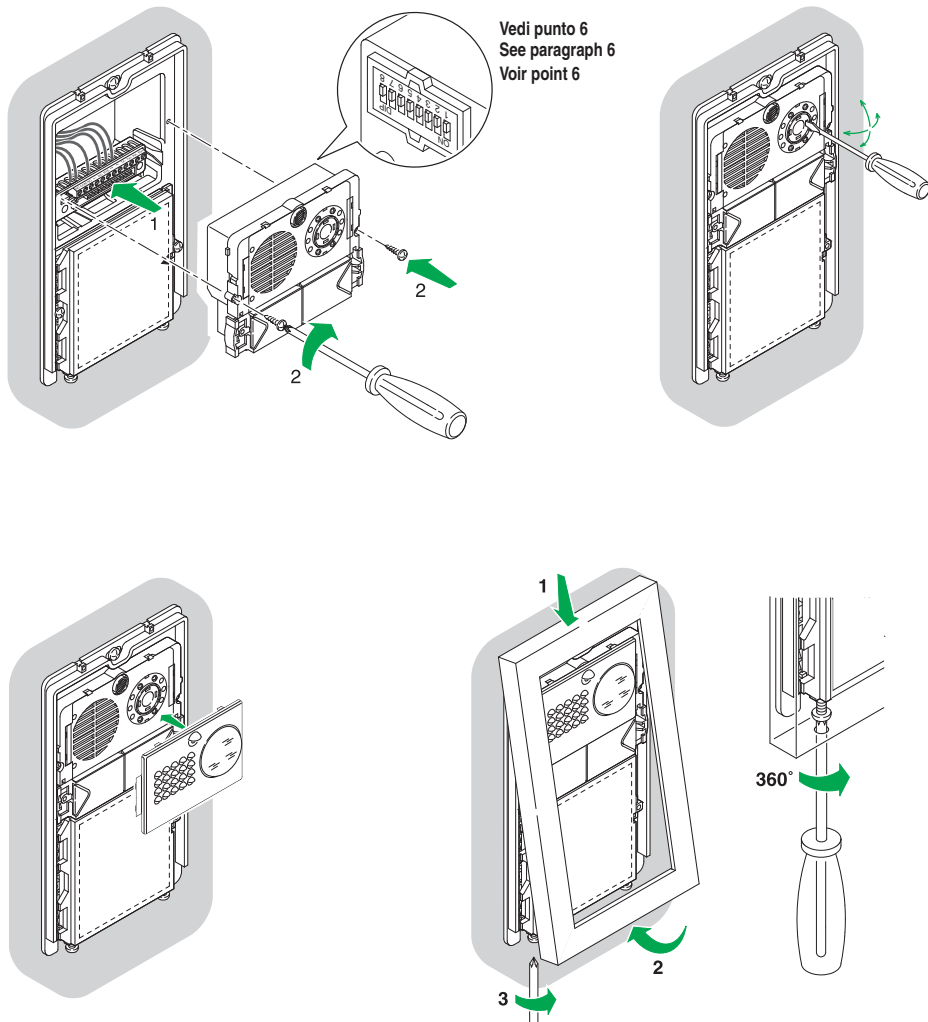

- IT** Montaggio e orientamento modulo telecamera.
- EN** Installing and adjusting the direction of the camera.
- FR** Montage et orientation module caméra.

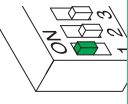
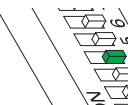
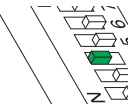

**IT** Tabella impostazioni dip switch posto esterno  
**EN** Table of external unit Dip switch settings.  
**FR** Tableau réglages Dip switches plaque de rue

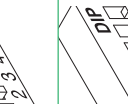
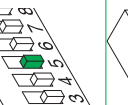
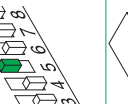
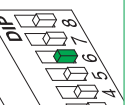
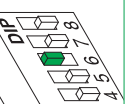
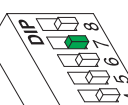
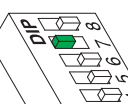
DIP	OFF	ON
1	 <p>Posto esterno 1 External unit 1 Plaque de rue 1</p>	 <p>Posto esterno 2 External unit 2 Plaque de rue 2</p>
4	 <p>Si attiva solo su comando da staffa Only activated on a command from the bracket S'active uniquement sur commande par bride</p>	 <p>Si attiva anche automaticamente* su chiamata da posto esterno e autoaccensione Also activated automatically* on receipt of a call from the external unit and when the self-ignition function is enabled *S'active également automatiquement* sur appel depuis la plaque de rue et auto-allumage</p>
5	 <p>2 secondi 2 seconds 2 secondes</p>	 <p>8 secondi 8 seconds 8 secondes</p>
6	 <p>2 secondi; *1 minuto se dip 4 ON Dip switch 4 ON 2 secondes ; *1 minute si dip 4 ON</p>	 <p>8 secondi; *3 minuti se dip 4 ON 8 seconds; *3 minutes if Dip switch 4 ON 8 secondes ; *3 minutes si dip 4 ON</p>
7	 <p>Non attivo Not active Non actif</p>	 <p>Attivo Active Actif</p>
8	 <p>Non attivo Not active Non actif</p>	 <p>Attivo Active Actif</p>

- IT** Kit monofamiliare: cablaggio monofase ponte Art. 1398.
- EN** Single-residence kit: Single-phase wiring for bridge Art. 1398.
- FR** Kit un appartement : câblage monophasé pont Art. 1398.

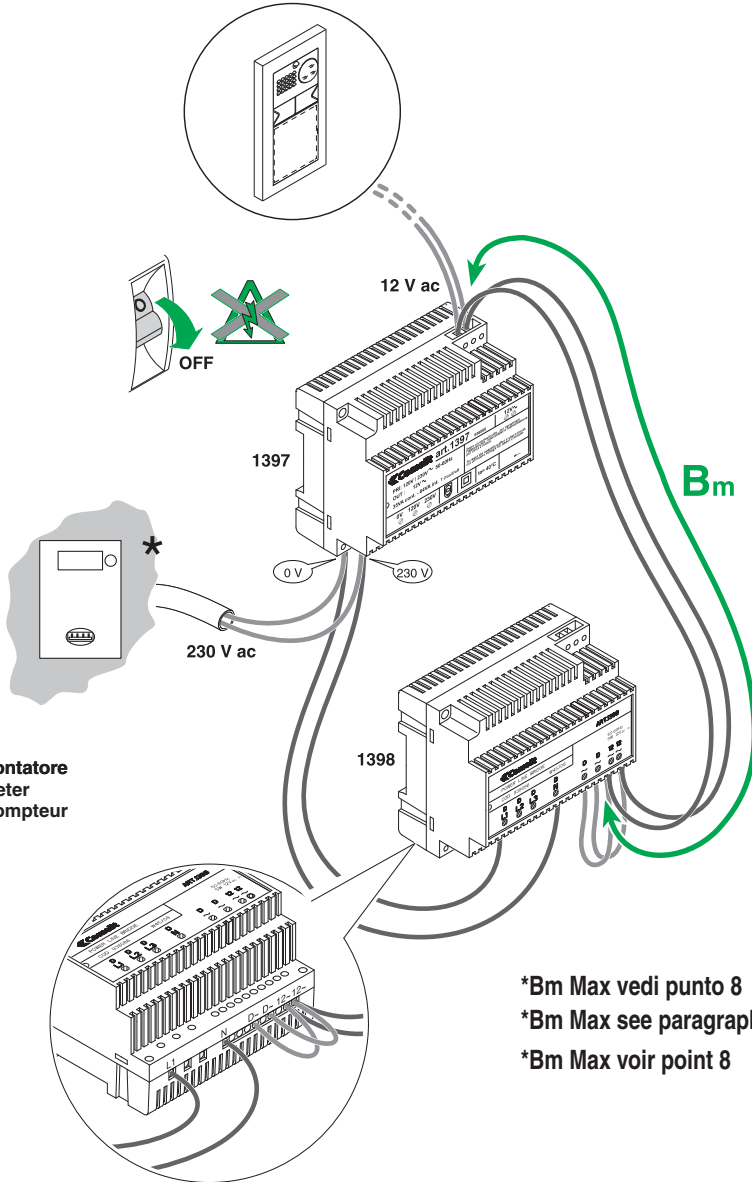

- IT Kit bifamiliare: cablaggio monofase ponti Art. 1398.
- EN Two-residence kit: Single-phase wiring for bridges Art. 1398.
- FR Kit deux appartements : câblage monophasé ponts Art. 1398.

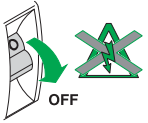

- \* Contatore
- \* Meter
- \* Compteur

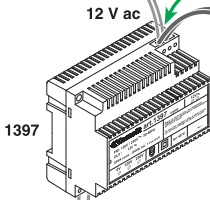
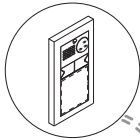

- \*Bb Max vedi punto 8
- \*Bb Max see paragraph 8
- \*Bb Max voir point 8

**B<sub>b</sub>**

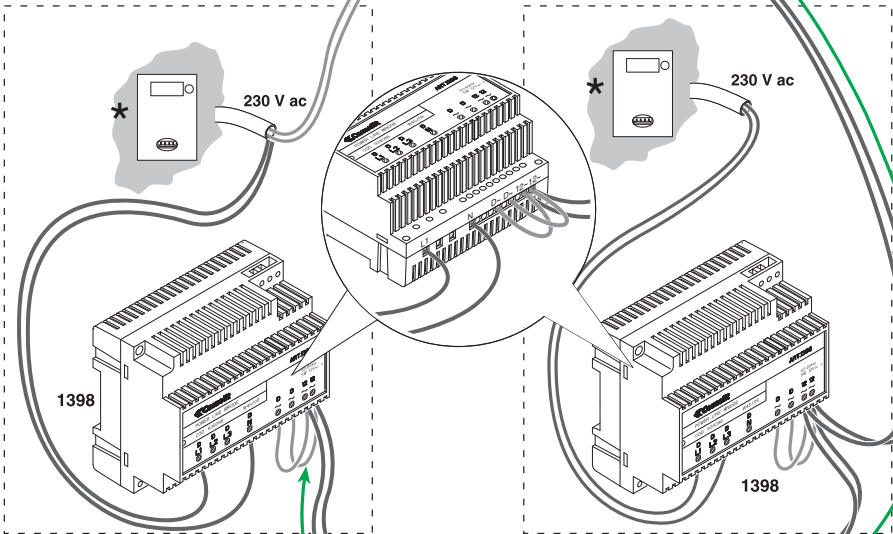

- IT** Kit bifamiliare con contatore parti comuni: cablaggio monofase ponti Art. 1398.
- EN** Two-residence kit with shared parts meter: Single-phase wiring for bridges Art. 1398.
- FR** Kit deux appartements avec compteur parties communes: câblage monophasé ponts Art. 1398.

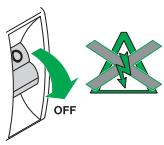

- \* Contatore
- \* Meter
- \* Compteur

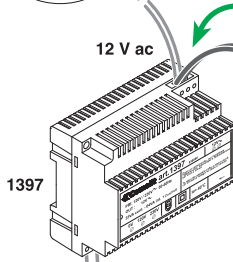
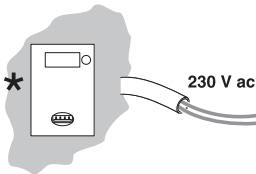





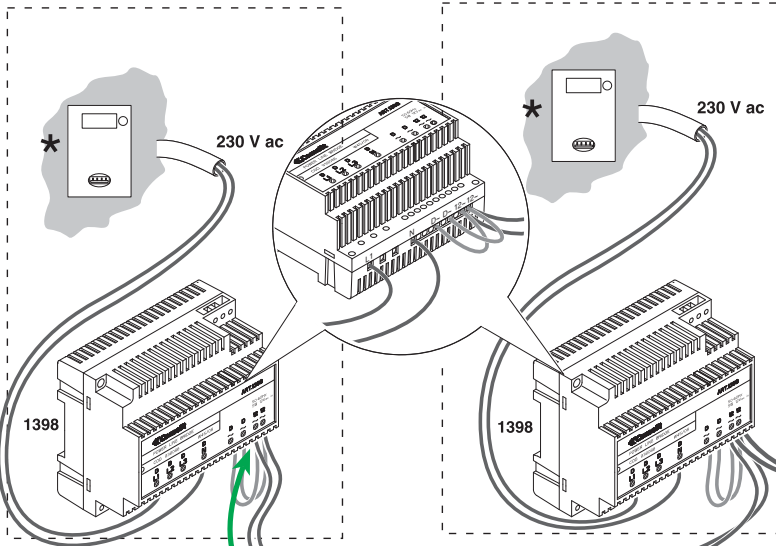



\*Bb Max vedi punto 8  
 \*Bb Max see paragraph 8  
 \*Bb Max voir point 8

**B<sub>b</sub>**



- IT** Distanze di collegamento  
**EN** Connection distances.  
**FR** Distances de connexion

		A Max	Bm Max	Bb Max	C Max
0,28 mm <sup>2</sup> (Ø 0,6 mm - Ø 6/10 AWG 23)					200 m
0,2 mm <sup>2</sup> (Ø 0.5 mm AWG 24)	UTP5 cat. 5 				400 m
0,5 mm <sup>2</sup> (Ø 0.8 mm AWG 20)		10 m	130 m	60 m	A + B
0,5 mm <sup>2</sup> (Ø 0.8 mm AWG 20)	Comelit Art. 4576-4578 	10 m	150 m	70 m	450 m
1 mm <sup>2</sup> (Ø 1,2 mm AWG 17)		25 m	150 m	70 m	150 m
1 mm <sup>2</sup> (Ø 1.2 mm AWG 17)	Comelit Art. 4577 	25 m	150 m	70 m	350 m
1 mm <sup>2</sup> (Ø 1.2 mm AWG 17)		25 m	100 m	50 m	A + B
1,5 mm <sup>2</sup> (Ø 1,4 mm AWG 15)		40 m	160 m	80 m	A + B
2,5 mm <sup>2</sup> (Ø 1,8 mm AWG 13)		60 m	180 m	110 m	A + B

- IT** **A:** distanza valida con carico massimo di 2 posti esterni, 2 ponti Art. 1398 e l'attivazione di una sola serratura per volta tra quelle alimentate dall'Art. 1397.  
 La distanza raddoppia se la serratura è alimentata in modo indipendente.  
**Bm:** Kit monofamiliare (1 ponte Art. 1398)  
**Bb:** kit bifamiliare (2 ponti Art. 1398)
- EN** **A:** distance applies with a maximum load of 2 external units, 2 bridges Art. 1398 and the activation of only one door-release device at a time for those powered by Art. 1397.  
 The distance doubles if the door-release device is powered independently.  
**Bm:** single-residence kit (1 bridge Art. 1398).  
**Bb:** two-residence kit (2 bridges Art. 1398).
- FR** **A:** distance valable avec charge maximum de 2 plaques de rue, 2 ponts Art. 1398 et l'activation d'une seule gâche à la fois parmi celles alimentées par l'Art. 1397.  
 La distance double si la gâche est alimentée de manière indépendante.  
**Bm :** Kit un appartement (1 pont Art. 1398)  
**Bb :** kit deux appartements (2 ponts Art. 1398)



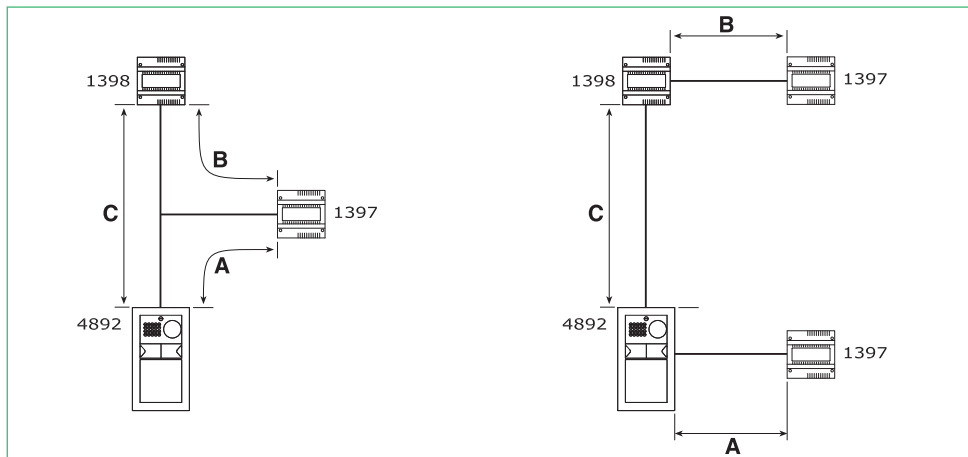

**(IT) Estensione massima unità abitativa \* servita dal ponte Art. 1398: 300m<sup>2</sup> circa.**

Attenzione! I gruppi di continuità impediscono il passaggio del segnale. L'insieme di tutti i punti di connessione (prese elettriche e ponti Art. 1398) utilizzabili per il sistema deve trovarsi in ingresso o in uscita del gruppo di continuità

\* Ambiente residenziale monofase o trifase (**non adatto per impianti industriali e alberghieri**).

**(EN) Maximum expanse of residential unit \* served by bridge Art. 300m<sup>2</sup> approx.**

Caution! Uninterruptible power supplies prevent the signal from passing through. All connection points (electrical sockets and bridges Art. 1398) which may be used by the system should be positioned at the input or the output of the uninterruptible power supply.

\* Single-phase or three-phase residential installation (**not suitable for industrial or hotel systems**).

**(FR) Extension maximum habitation \* servie par le pont Art. 1398: 300m<sup>2</sup> environ.**

Attention ! Les onduleurs empêchent le passage du signal. L'ensemble de tous les points de connexion (prises électriques et ponts Art. 1398) utilisables pour le système doit se trouver en entrée ou en sortie de l'onduleur

\* Milieu résidentiel monophasé ou triphasé (**non adapté aux installations industrielles et hôtelières**).

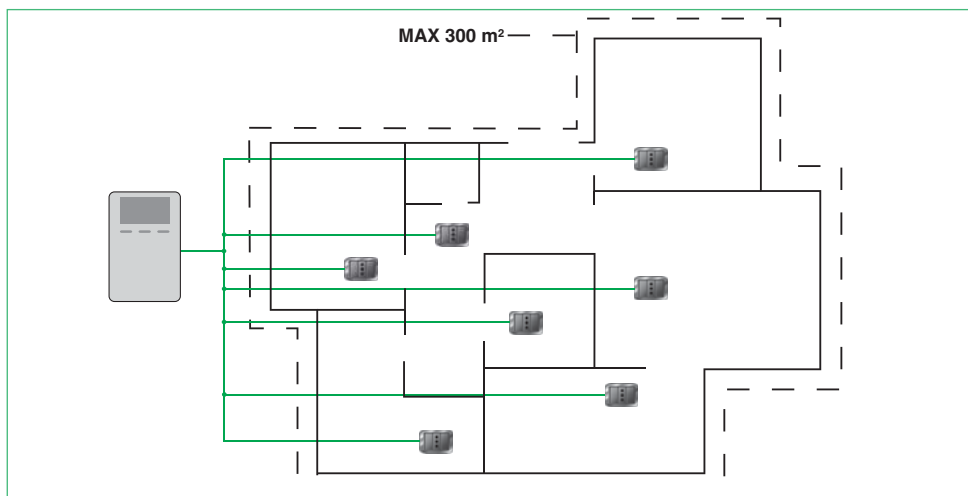

9

- IT Accensione alimentazione generale.
- EN Switching on the main power supply.
- FR Allumage alimentation générale.

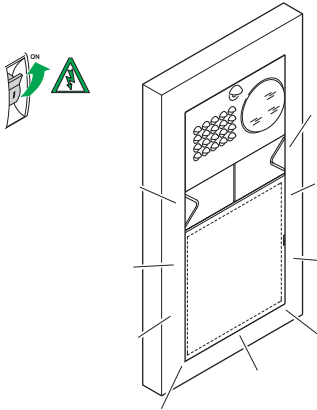

- IT Kit monofamiliare: corrispondenza staffa / pulsante di chiamata.
- EN Single-residence kit: bracket / call pushbutton alignment.
- FR Kit un appartement : correspondance bride / touche d'appel.

10A

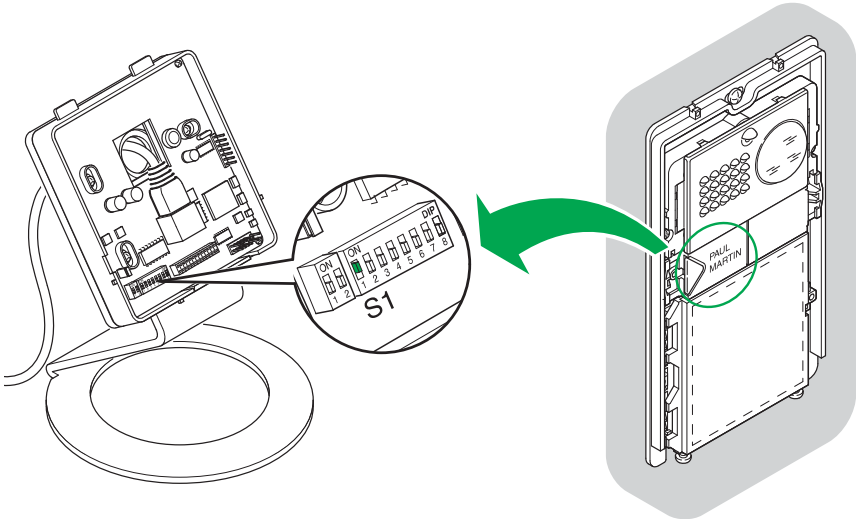

- IT** Kit bifamiliare: corrispondenza staffa / pulsante di chiamata e alimentatore monitor / ponte Art. 1398
- EN** Two-residence kit: bracket / call pushbutton and monitor power supply / bridge Art. 1398 alignment.
- FR** Kit deux appartements : correspondance bride / touche d'appel et alimentateur moniteur / pont Art. 1398

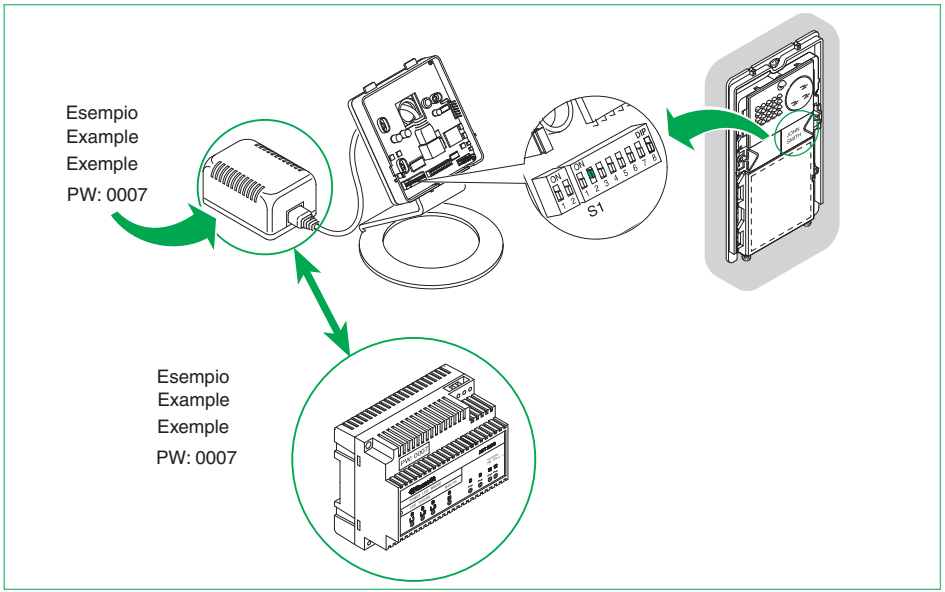
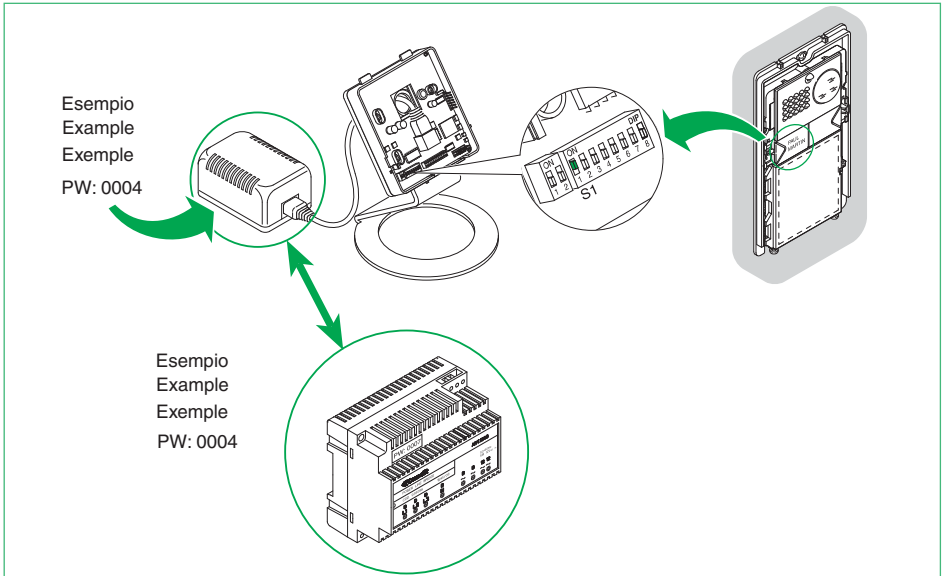

- IT** Montaggio monitor.
- EN** Installing the monitor.
- FR** Montage moniteur.

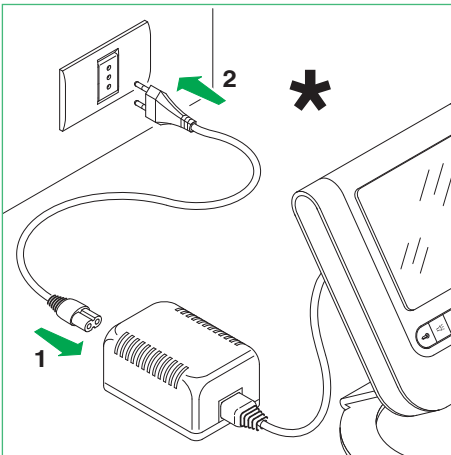
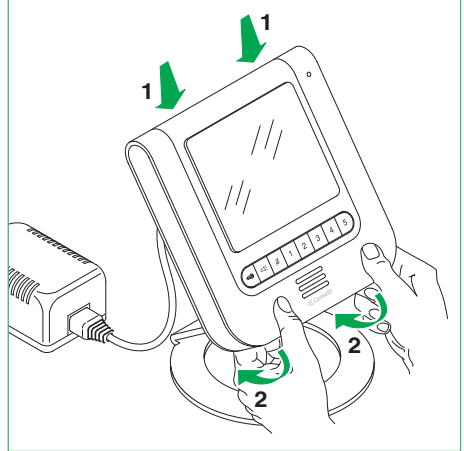
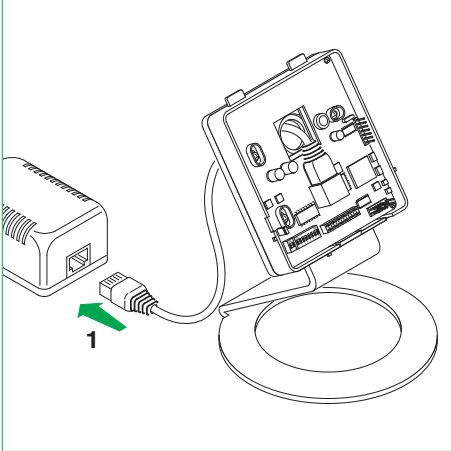

- IT** \* Non utilizzare ciabatte con interruttore
- EN** \* Do not use power strips fitted with switches
- FR** \* Ne pas utiliser des blocs ménagers avec interrupteur

- IT** Segnalazione anomalie e possibili soluzioni.  
**EN** Fault indication and troubleshooting.  
**FR** Signalisation anomalies et solutions possibles.

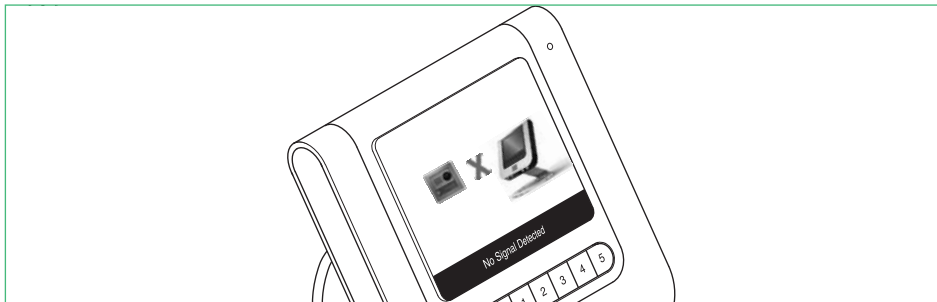

- IT** In caso di connessione mancante attendere 1 minuto. Se la segnalazione si ripresenta assicurarsi:
- Che il posto esterno sia correttamente cablato (punto 2) e che sia alimentato (punto 9).
  - Che il ponte Art. 1398 sia correttamente cablato (punto 7A, 7B o 7C).
  - Che ci sia corrispondenza tra la password del ponte Art. 1398 e l'alimentatore monitor della stessa unità abitativa.
  - Che siano rispettate le distanze di installazione (punti 2 e 8).
- FR** En cas d'absence de connexion, attendre 1 minute Si la signalisation se présente à nouveau, vérifier :
- que la plaque de rue est correctement câblée (point 2) et qu'elle est alimentée (point 9).
  - que le pont Art. 1398 est correctement câblé (point 7A, 7B ou 7C).
  - qu'il y a correspondance entre le mot de passe du pont Art. 1398 et l'alimentateur moniteur de la même habitation.
  - que les distances d'installation sont respectées (ponts 2 et 8).
- EN** If there is no connection, wait for 1 minute. If the indication appears again, make sure:
- That the external unit is wired correctly (paragraph 2) and that it is receiving power (paragraph 9).
  - That the bridge Art. 1398 is wired correctly (paragraph 7A, 7B or 7C).
  - That the password for bridge Art. 1398 is the same as the password for the power supply of the monitor in the same residential unit.
  - That the installation distances have been observed (paragraphs 2 and 8).

- IT Utilizzo relé del modulo numero civico (Relé 2). Vedi variante PW/AAA
- EN Using the house number module relay (Relay 2). See PW/AAA variant
- FR Utilisation relais du module numéro de rue (relais 2). Voir variante PW/AAA

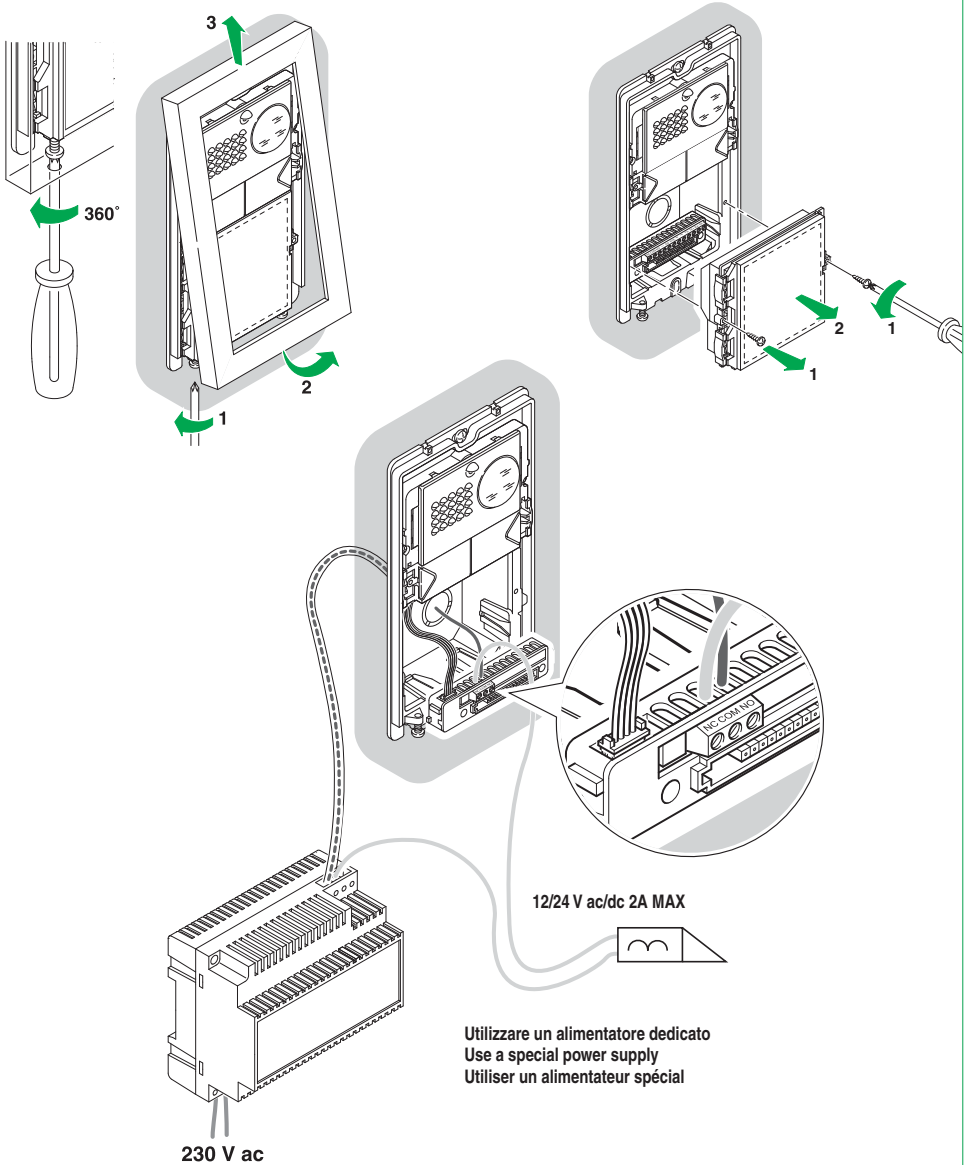

- IT** Installazione monitor supplementari secondari (MAX 14 per unità abitativa).
- EN** Installing additional secondary monitors (MAX 14 per residential unit).
- FR** Installation moniteurs supplémentaires secondaires (maxi 14 par habitation).

**IT** Per ogni monitor supplementare impostare il dipswitch S1 con lo stesso indirizzo del monitor principale della stessa unità abitativa (Esempio indirizzo 1).

**EN** For every additional monitor, set dip switch S1 so that the address is the same as for the main monitor of that residential unit (Example: address 1).

**FR** Pour chaque moniteur supplémentaire, programmer le Dip switch S1 avec la même adresse que celle du moniteur principal de la même habitation (exemple adresse 1)

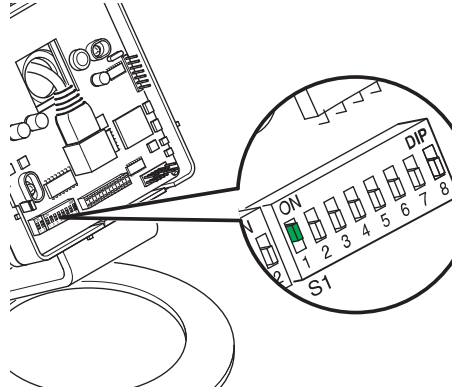

**A**

**IT** Sul monitor supplementare impostare i dipswitch 5, 6, 7, 8 di S1 con un codice diverso per ogni monitor ( MAX 14) scegliendo tra quelli nella tabella seguente. Il codice impostato individua il numero dell'apparecchio associato alla chiamata intercomunicante (Esempio. con 5 ON intercom 2).

**EN** On the additional monitor, set dip switches 5, 6, 7, 8 of S1 with a different code for every monitor (MAX 14), selecting from the values listed in the table below. The selected code identifies the number of the device associated with the intercom call (Example: with 5 ON intercom 2).

**FR** Sur le moniteur supplémentaire, programmer les Dip switches 5, 6, 7, 8 de S1 avec un code différent pour chaque moniteur ( maxi 14) en choisissant parmi ceux du tableau suivant. Le code programmé correspond au numéro de l'appareil associé à l'appel intercommunicant (exemple avec 5 ON intercom 2).

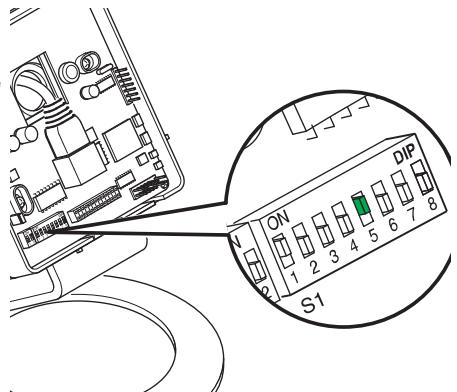

**B**

Codice intercom Intercom code Code intercom	1	2	3	4	5	6	7	8	9	10	11	12	13	14
Dip switch ON	*	5	6	5,6	7	5,7	6,7	5,6,7	8	5,8	6,8	5,6,8	7,8	5,7,8

**(IT)** \*Dip 5, 6, 7, 8 OFF: Monitor principale

**(EN)** \*Dip 5, 6, 7, 8 OFF: Main monitor

**(FR)** \*Dip 5, 6, 7, 8 OFF : Moniteur principal

**(IT)** Prendere nota della password modem sull'etichetta del ponte Art. 1398 dell'unità abitativa interessata

**(EN)** Make a note of the modem password on the label of the bridge Art. 1398 for the relevant residential unit.

**(FR)** Prendre note du mot de passe modem sur l'étiquette du pont Art. 1398 de l'habitation intéressée

**C**

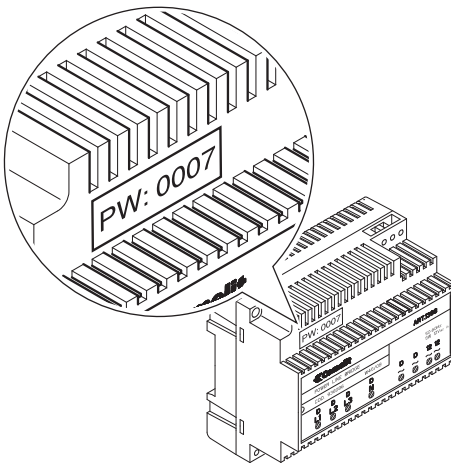

**D**

**(IT)** Dopo aver abilitato il menu installatore (punto 15), impostare il codice del modem come descritto al punto 20

**(EN)** After enabling the installer menu (paragraph 15), set the modem code as described in paragraph 20.

**(FR)** Après avoir validé le menu d'installation (point 15), programmer le code du modem comme décrit au point 20



- IT** Abilitare e disabilitare il menu installatore.
- EN** Enabling and disabling the installer menu using.
- FR** Valider et invalider le menu d'installation.

- IT** La procedura é valida per tutte le staffe, monofamiliari e bifamiliari
- EN** The procedure applies to all single-residence and two-residence brackets.
- FR** La procédure est valable pour toutes les brides, pour un appartement et deux appartements

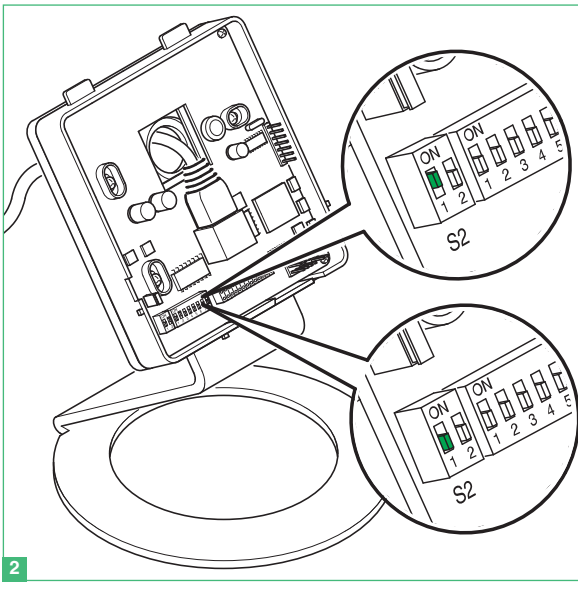
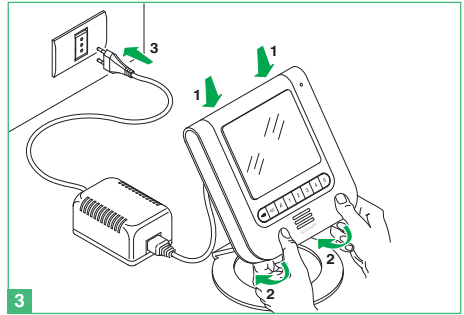
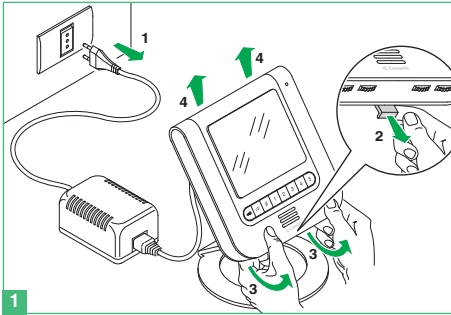

Per abilitare Dip 1 di S2 su ON  
 To enable Dip 1 of S2 - ON  
 Pour valider le Dip 1 de S2 sur ON

Per disabilitare Dip 1 di S2 su OFF  
 To disable Dip 1 of S2 - OFF  
 Pour invalider le Dip 1 de S2 sur OFF

## 16 IMPOSTAZIONE LINGUA MENU

Al primo accesso al menu (pulsante 1), viene richiesto di impostare la lingua di utilizzo.

Selezionare la lingua desiderata con e .

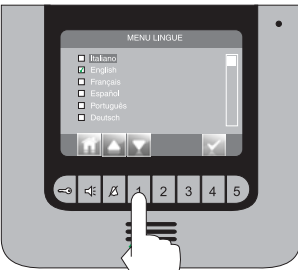

uscire dal menu premendo e confermare la scelta con e .

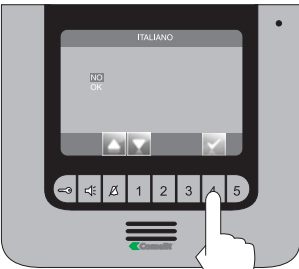

## 17 ACCEDERE AL MENU INSTALLATORE

Per accedere al menu installatore premere il pulsante 1.

- 1 Impostazioni speciali (vedi punti 23, 24, 26).
- 2 Configura pulsanti (vedi punto 22).
- 3 Configura monitor (vedi punti 20, 25, 27, 28).

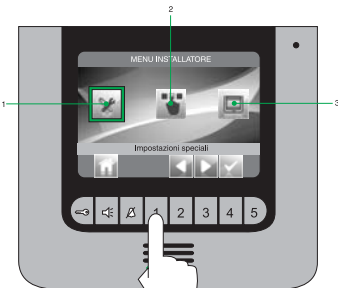

## 18 DESCRIZIONE MENU INSTALLATORE

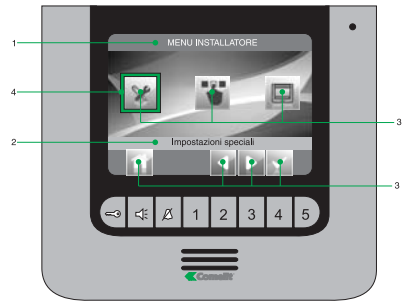

- 1 Titolo menu attualmente aperto.
- 2 Titolo menu selezionato.
- 3 Icone menu.
- 4 Cornice indicante il menu selezionato.
- 5 Icone funzione abbinate ai pulsanti.

## 19 DESCRIZIONE ICONE ABBINATE AI PULSANTI

Le icone determinano la funzione svolta dal pulsante sottostante come descritto di seguito:

Permette di arretrare di un livello o uscire dal menu.

Permette di aprire / confermare il menu selezionato.

Permette di tornare al menu principale.



Permette di spostarsi all'interno del menu / aumentare e diminuire un valore selezionato.

**20 CONFIGURAZIONE PASSWORD MODEM**

Dal menu installatore (pulsante 1) accedere al menu "Configura monitor" con **1** e **4**.

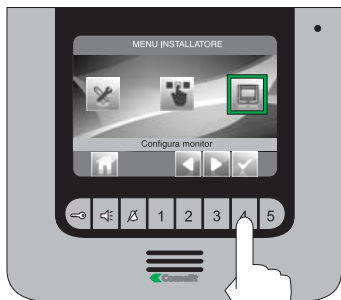

Accedere al menu "Configura staffa".

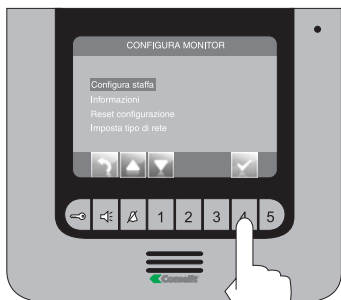

Accedere al menu "Cambia password".



Inserire la password del ponte collegato all'unità abitativa interessata (punto 14C) modificando il numero selezionato con i pulsanti **1** e **4**. Per passare al numero successivo o precedente usare i pulsanti **1** e **4**.



Premere il pulsante **1** per uscire e salvare le modifiche.

Se concludere le operazioni di configurazione disabilitare il menu installatore.

## 21 SEGNALAZIONE ANOMALIE E POSSIBILI SOLUZIONI



In caso di connessione mancante con il posto interno, attendere 1 minuto. Se la segnalazione si ripresenta assicurarsi:

- Che il monitor secondario abbia lo stesso indirizzo del monitor principale dell'unità abitativa interessata (punto 14A).
- Che il monitor principale sia alimentato (punto 11).
- Che sia stata inserita la password corretta (punto 14C e 20).
- Che siano state rispettate le distanze di installazione (punto 8).



In caso di connessione mancante con il posto esterno assicurarsi:

- Che il posto esterno sia correttamente cablato (punto 2) e che sia alimentato (punto 8).
- Che il ponte Art. 1398 sia correttamente cablato (punto 7A, 7B, 7C).
- Che ci sia corrispondenza tra la password del ponte Art. 1398 e l'alimentatore monitor della stessa unità abitativa.
- Che siano rispettate le distanze di installazione (punto 8).

## 22 CONFIGURAZIONE PULSANTI

Il kit dispone di 2 relé (relé 1 e relé 2) per ogni posto esterno connesso.

È possibile configurarne il funzionamento sia durante che in assenza di chiamata (impianto a riposo).

Con ogni pulsante configurato per il comando dei relé, è possibile attivare contemporaneamente 2 relé\* al massimo.

In caso di chiamata, uno dei relé attivabili è necessariamente quello della porta chiamante.

### • PULSANTE CHIAVE

Dal menu installatore (pulsante 1) accedere al menu "Configura pulsanti" con e .

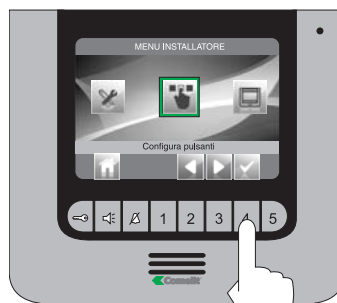

Selezionare l'icona "Configura Pulsante Chiave" con i pulsanti e .

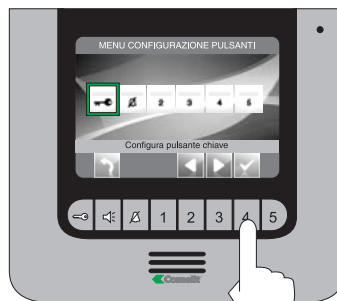

\* In caso di attivazione contemporanea di 2 relé disporre per uno dei carichi un alimentatore dedicato.

Selezionare la modalità per la quale si vuole modificare la funzione con i pulsanti e confermare la scelta premendo .

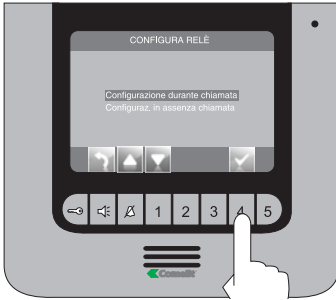

Selezionare i campi modificabili con i pulsanti e modificare il valore con o .



Selezionare i campi modificabili con i pulsanti e modificare il valore con o .



Premere il pulsante per uscire e salvare le modifiche.

Se concludere le operazioni di configurazione disabilitare il menu installatore.

## • PULSANTE PRIVACY / DOTTORE

- La funzione Privacy permette l'esclusione della chiamata dal posto esterno o intercomunicante.
- La funzione Dottore permette l'azionamento automatico dell'apriporta (relé 1) su chiamata da posto esterno.
- La funzione Dottore + Privacy oltre a disattivare la suoneria del citofono come nella funzione Privacy, permette l'azionamento automatico dell'apriporta (relé 1) su chiamata da posto esterno.

Dal menu installatore (pulsante 1) accedere al menu "Configura pulsanti" con e .



Selezionare l'icona "Configura privacy /dottore" con i pulsanti e confermare la scelta premendo .



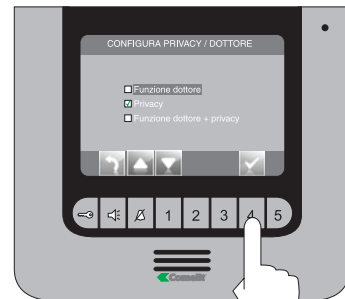

Selezionare la funzione desiderata con i pulsanti e confermare la scelta premendo .





Se concludere le operazioni di configurazione disabilitare il menu installatore.

• **PULSANTI 2 - 3 - 4 - 5**





I pulsanti 2, 3, 4 e 5 possono essere programmati tutti con lo stesso procedimento. Di seguito viene illustrata la programmazione del pulsante 2.

Dal menu installatore (pulsante 1) accedere al menu "Configura pulsanti" con   e .

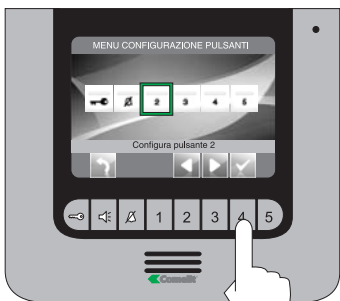

Selezionare l'icona "Configura Pulsante 2" con i pulsanti   e confermare la scelta premendo .



Selezionare la funzione desiderata con i pulsanti  , confermare la scelta premendo  e premere successivamente il pulsante .



Se è stata selezionata la funzione "Intercomunicante" nel passo precedente, occorre associare il pulsante ad un posto interno.

INTERCOM X (vedi punto 14 B).

GENERALE INTERNA: Invia una chiamata a tutti i monitor della stessa unità abitativa.

GENERALE ESTERNA: Invia una chiamata a tutti i monitor dell'altra unità abitativa.

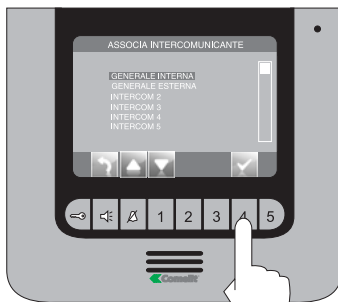

Se è stata selezionata la funzione "Autoaccensione" nel passo precedente, occorre associare il pulsante ad uno o entrambi i posti esterni



Se è stata selezionata la funzione "Attivazione relé" nel passo precedente, seguire la procedura indicata per la programmazione del Pulsante chiave

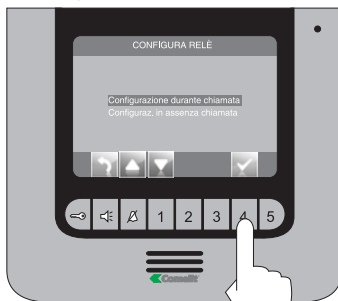

Premere il pulsante  per uscire e salvare le modifiche.

Se concluse le operazioni di configurazione disabilitare il menu installatore.

## 23 ATTIVAZIONE RIPETIZIONE SUONERIA

Con questa funzione attivata il monitor ripeterà la suoneria tre volte dopo la ricezione di una chiamata

Dal menu installatore (pulsante 1) accedere a "Impostazioni speciali" con e .



Accedere al menu "Imposta ripetizione suoneria"

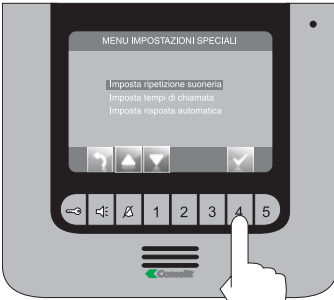

Confermare la scelta premendo .

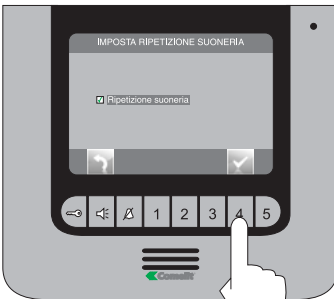

Premere il pulsante per uscire e salvare le modifiche.

Se concludere le operazioni di configurazione disabilitare il menu installatore.

## 24 ATTIVAZIONE RISPOSTA AUTOMATICA

Con questa funzione impostata, la fonica viene automaticamente attivata dopo la ricezione di una chiamata

Dal menu installatore (pulsante 1) accedere al menu "Impostazioni speciali" con e .

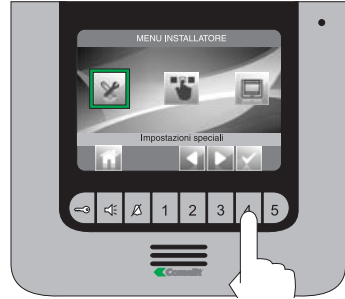

Accedere al menu "Imposta risposta automatica"



Confermare la scelta premendo .



Premere il pulsante per uscire e salvare le modifiche.

Se concludere le operazioni di configurazione disabilitare il menu installatore.

25

## VISUALIZZA INFORMAZIONI

Dal menu installatore accedere al menu "Impostazioni speciali" con e .

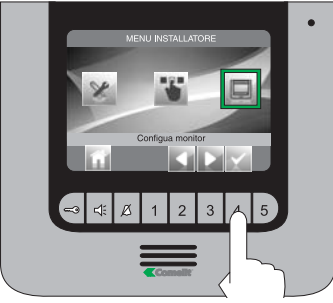

Accedere al menu "Informazioni"

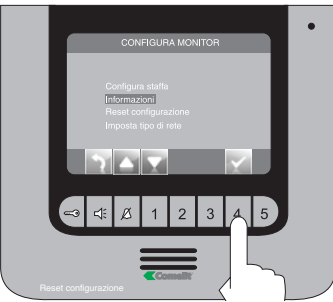

Se concludere le operazioni di configurazione disabilitare il menu installatore.

26

## CONFIGURAZIONE TEMPI DI CHIAMATA

All'interno di questo menu è possibile modificare:

- Tempo attesa risposta: tempo massimo oltre il quale la comunicazione termina in assenza di risposta
- Tempo conversazione: durata di una conversazione tra posto interno e posto esterno.
- Tempo conversazione intercom: durata di una conversazione intercomunicante.
- Ritardo di spegnimento: dopo una chiamata, tempo di attesa dall'attivazione di un relé allo spegnimento del monitor.

Dal menu installatore (pulsante 1) accedere a "Impostazioni speciali" con e .

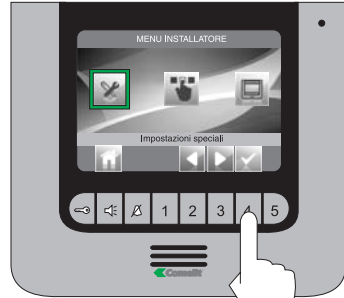

Accedere al menu "Imposta tempi di chiamata"

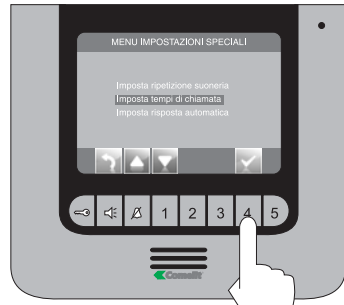

Selezionare il valore che si vuole modificare con i pulsanti e confermare la scelta premendo .

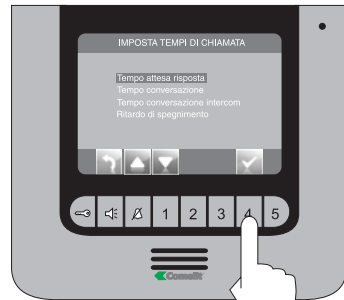



Modificare il valore con i pulsanti



Premere il pulsante per uscire e salvare le modifiche.

Se concludere le operazioni di configurazione disabilitare il menu installatore.

Confermare la scelta premendo .



**27**

## RESET CONFIGURAZIONE

**Questa operazione ripristinerà tutte le impostazioni di fabbrica, annullando tutte le modifiche apportate**

Dal menu installatore accedere al menu "Configura monitor" con e .

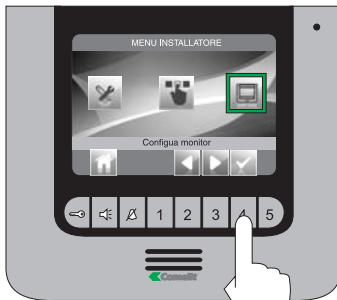

Selezionare il menu "reset configurazione" con i pulsanti .

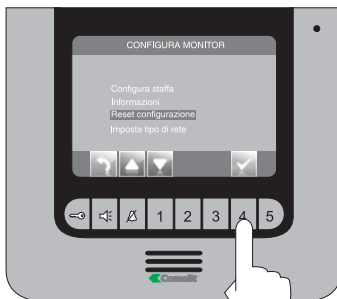

**28**

## MENU IMPOSTA TIPO DI RETE

Dal menu installatore accedere al menu "Configura monitor" con e .

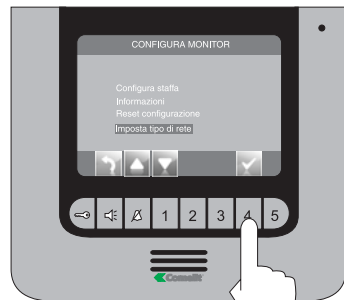
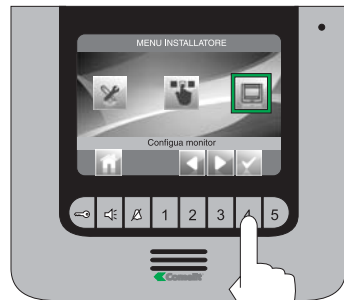

**NON MODIFICARE ASSOLUTAMENTE QUESTO VALORE.**

Il valore impostato di fabbrica è IPOWER.

## 16 SETTING THE MENU LANGUAGE

When you first enter the menu (pushbutton 1), you will be asked to set the language.

Select the desired language using and and .



Exit the menu by pressing and confirm your selection using and .

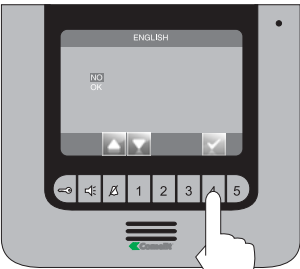

## 17 ENTERING THE INSTALLER MENU

To enter the installer menu, press pushbutton 1.

- 1 Special settings (see paragraphs 23, 24 and 26).
- 2 Program pushbuttons (see paragraph 22).
- 3 Program monitor (see paragraphs 20, 25, 27 and 28).

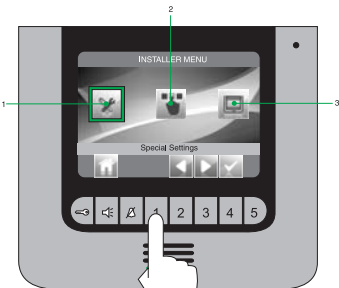

## 18 DESCRIPTION OF THE INSTALLER MENU

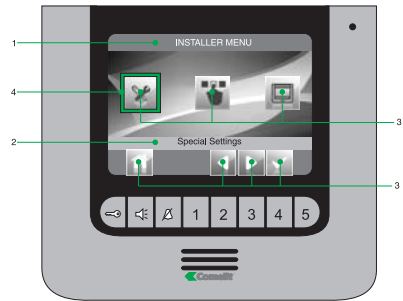

- 1 Name of menu currently open.
- 2 Name of menu selected.
- 3 Menu icons.
- 4 Frame indicating menu selection.
- 5 Icons corresponding to the pushbutton functions.

## 19 DESCRIPTION OF THE ICONS CORRESPONDING TO THE PUSHBUTTONS

The icons identify the function performed by the pushbuttons underneath, as follows:



Used to go back one level or exit the menu.



Used to open / confirm the selected menu.



Used to return to the main menu.



Used to scroll through the menu / increase and decrease a selected value.

## 20 SETTING THE MODEM PASSWORD

From the installer menu (pushbutton 1), enter the "Program monitor" menu using **[Left]** and **[Right]**.

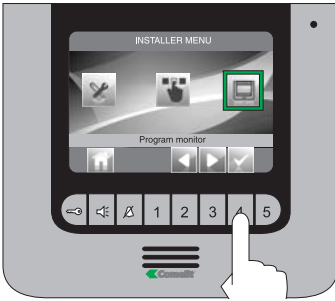

Enter the "Set bracket" menu.



Enter the "Change password" menu.

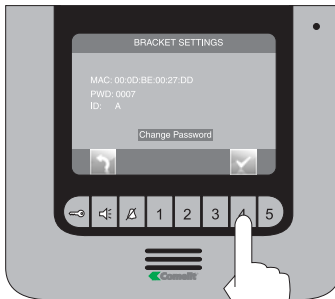

Enter the password for the bridge connected to the relevant residential unit (paragraph 14C), adjusting the number selected using pushbuttons **[Left]** and **[Right]**. To move on to the following number or the previous number, use pushbuttons **[Left]** and **[Right]**.



Press pushbutton **[Left]** to exit and save the changes.

Once you have completed the programming procedures, disable the installer menu.

## 21 FAULT INDICATION AND TROUBLESHOOTING



If there is no connection with the internal unit, wait for 1 minute. If the indication appears again, make sure:

- That the secondary monitor has the same address as the main monitor for the relevant residential unit (paragraph 14A).
- That the main monitor is receiving power (paragraph 11).
- That the correct password has been entered (paragraph 14C and 20).
- That the installation distances have been observed (paragraph 8).



If there is no connection with the external unit, make sure:

- That the external unit is wired correctly (paragraph 2) and that it is receiving power (paragraph 8).
- That the bridge Art. 1398 is wired correctly (paragraph 7A, 7B, 7C).
- That the password for bridge Art. 1398 is the same as the password for the power supply of the monitor in the same residential unit.
- That the installation distances have been observed (paragraph 8).

## 22 PROGRAMMING THE PUSHBUTTONS

The kit has 2 relays (relay 1 and relay 2) for each external unit connected.

Their operation may be programmed either during a call or when the system is in standby.

When every pushbutton has been programmed for relay control, a maximum of 2 relays\* may be activated at the same time.

In the event of a call, one of the relays activated must correspond to the door from which the call is made.

### • KEY PUSHBUTTON

From the installer menu (pushbutton 1), enter the “Buttons programming” menu using and .



Select the “Program key button” icon using pushbuttons and confirm your selection by pressing .

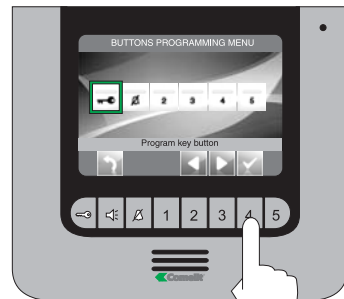

\* If 2 relays are activated at the same time, provide a special power supply for one of the loads.

Select the mode for which you wish to modify the function using pushbuttons and confirm your selection by pressing .

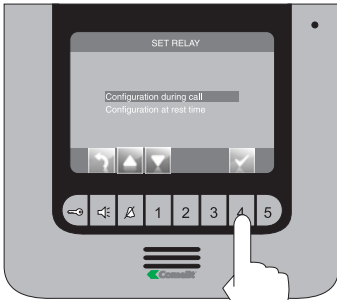

Select the fields you wish to modify using pushbuttons and adjust the values using or .



Select the fields you wish to modify using pushbuttons and adjust the values using or .



Press pushbutton to exit and save the changes.

Once you have completed the programming procedures, disable the installer menu.

## • PRIVACY / DOCTOR BUTTON

- The Privacy mode disables calls from the external unit or intercom.
- The Doctor mode enables automatic activation of the door-release function (relay 1) in response to a call from the external unit.
- The Doctor + Privacy mode, as well as disabling the intercom ringtone melody in the same way as the Privacy mode, also enables automatic activation of the door-release function (relay 1) in response to a call from the external unit.

From the installer menu (pushbutton 1), enter the "Buttons programming" menu using and .



Select the "Privacy/Doctor settings" icon using pushbuttons and confirm your selection by pressing .

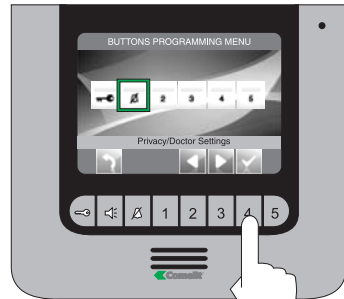

Select the desired function using pushbuttons and confirm your selection by pressing .

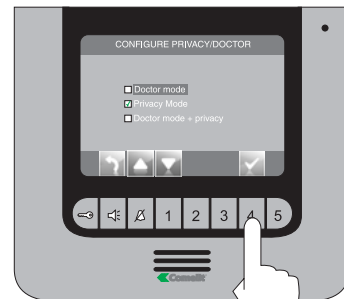

Press pushbutton to exit and save the changes.

Once you have completed the programming procedures, disable the installer menu.

• **PUSHBUTTONS 2 - 3 - 4 - 5**

Pushbuttons 2, 3, 4 and 5 may be all programmed using the same procedure. The programming procedure for pushbutton 2 is illustrated below.

From the installer menu (pushbutton 1), enter the "Buttons programming" menu using and .



Select the "Program Button 2" icon using pushbuttons and and confirm your selection by pressing .

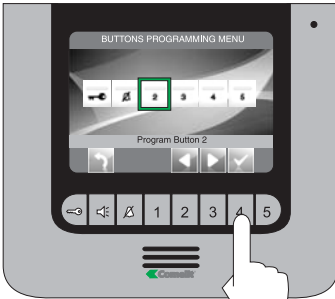

Select the desired function using pushbuttons and , confirm your selection by pressing and then press button .

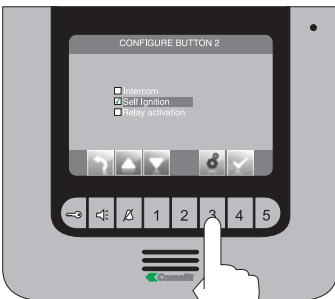

If the "Intercom" function was selected in the previous step, the pushbutton must be assigned to an internal unit.

INTERCOM X (see paragraph 14 B).

GENERAL INTERNAL: Make a call to all monitors in the same residential unit.

GENERAL EXTERNAL: Make a call to all monitors in the other residential unit.

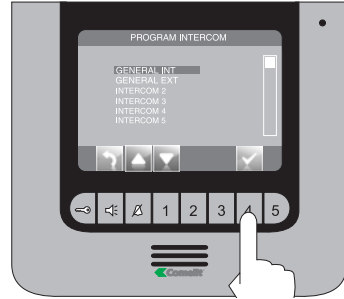

If the "Self-ignition" function was selected in the previous step, the pushbutton must be assigned to one or both of the internal units.

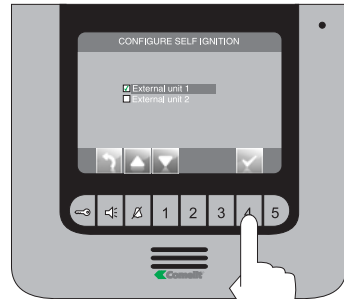

If the "Relay activation" function was selected in the previous step, follow the procedure described for Key pushbutton programming.

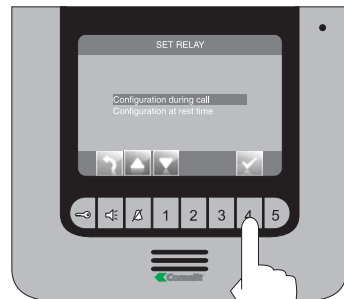

Press pushbutton to exit and save the changes.

Once you have completed the programming procedures, disable the installer menu.

## 23 ACTIVATING RINGTONE REPETITION

When this function is active, the monitor will repeat the ringtone three times after a call is received.

From the installer menu (pushbutton 1), enter the "Special settings" menu using **⏪** and **⏩**.



Enter the "Set tone repetition" menu.

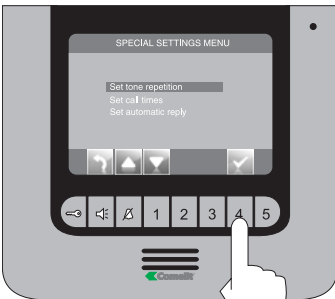

Confirm your selection by pressing **⏩**.

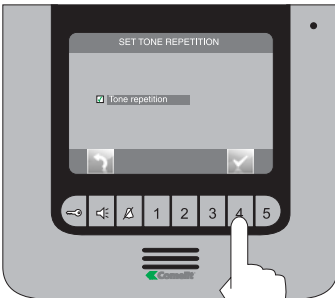

Press pushbutton **⏩** to exit and save the changes.

Once you have completed the programming procedures, disable the installer menu.

## 24 ACTIVATING THE AUTOMATIC RESPONSE

When this function is selected, the audio line is activated automatically after a call is received.

From the installer menu (pushbutton 1), enter the "Special settings" menu using **⏪** and **⏩**.



Enter the "Set automatic reply" menu.

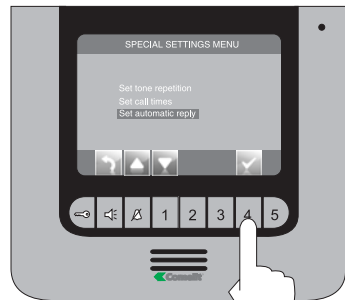

Confirm your selection by pressing **⏩**.

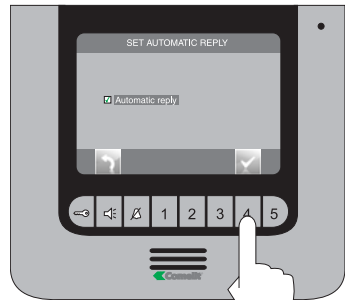

Press pushbutton **⏩** to exit and save the changes.

Once you have completed the programming procedures, disable the installer menu.

25

## DISPLAYING INFORMATION

From the installer menu (pushbutton 1), enter the "Special settings" menu using **[Left]** and **[Right]**.

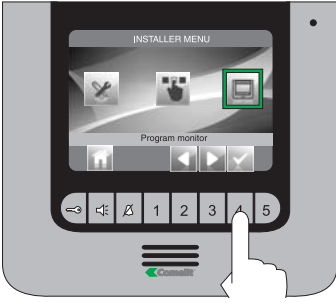

Enter the "Information" menu.

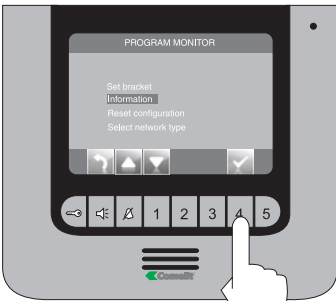

Once you have completed the programming procedures, disable the installer menu.

26

## PROGRAMMING CALL TIMES

This menu can be used to modify:

- Awaiting response time: maximum time beyond which communication will be terminated if there is no response.
- Talk time: duration of a conversation between an internal unit and the porter module.
- Intercom talk time: duration of an intercom conversation.
- Shut-down delay: after a call, the amount of time before a relay is activated to shut down the monitor.

From the installer menu (pushbutton 1), enter the "Special settings" menu using **[Left]** and **[Right]**.

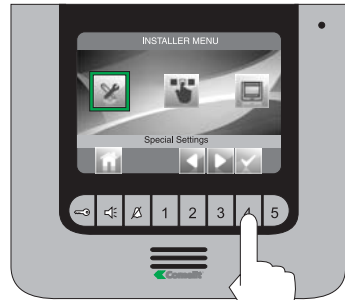

Enter the "Set call times" menu.

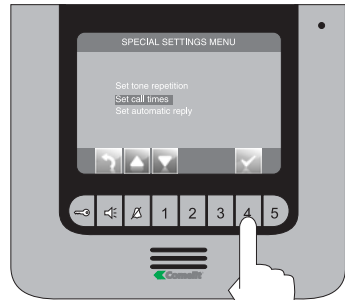

Select the value you wish to modify using pushbuttons **[Left]** and **[Right]** and confirm your selection by pressing **[Enter]**.

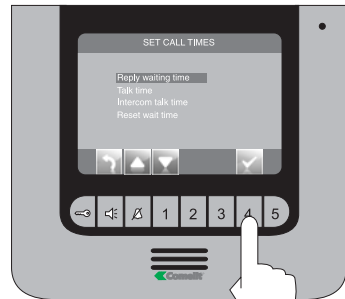



Modify the value using pushbuttons.  





Press pushbutton  to exit and save the changes.



Once you have completed the programming procedures, disable the installer menu.

## 27 RESET CONFIGURATION

**This procedure will restore all default settings, deleting all modifications made previously.**

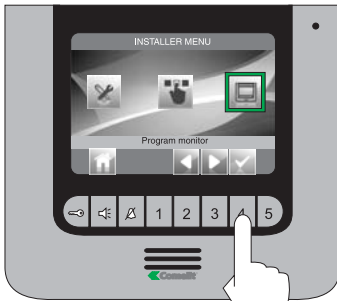
From the installer menu (pushbutton 1), enter the "Program monitor" menu using   and .



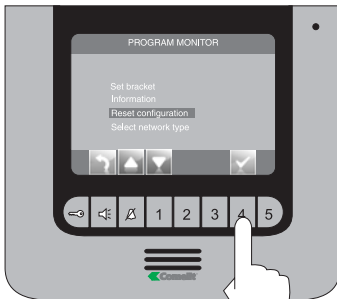

Select the "Reset configuration" menu using pushbuttons  .

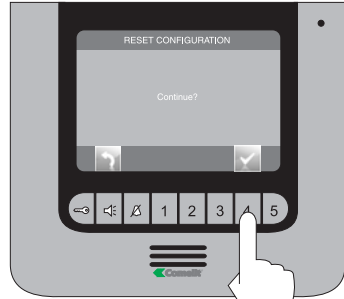

Confirm your selection by pressing .



## 28 SELECT TYPE OF NETWORK MENU

From the installer menu (pushbutton 1), enter the "Program monitor" menu using   and .

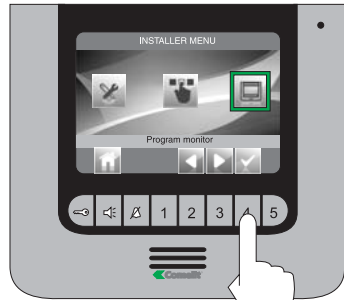

**DO NOT UNDER ANY CIRCUMSTANCES MODIFY THIS VALUE.**

The default value is IPOWER.

**16**

**RÉGLAGE LANGUE MENU**

Au premier accès au menu (touche 1), choisir la langue que l'on désire utiliser.

Sélectionner la langue désirée avec et et .

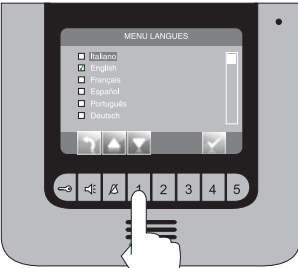

quitter le menu en appuyant sur et confirmer le choix avec et .

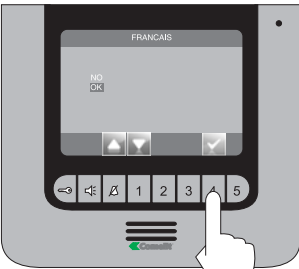

**17 ACCÉDER AU MENU D'INSTALLATION**

Pour accéder au menu d'installation, appuyer sur le touche 1.

- 1 Réglages spéciaux (voir points 23, 24, 26).
- 2 Configuration touches (voir point 22).
- 3 Configuration moniteur (voir points 20, 25, 27, 28).

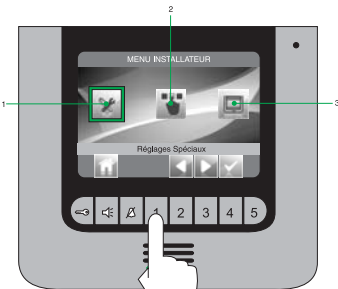

**18**

**DESCRIPTION MENU D'INSTALLATION**

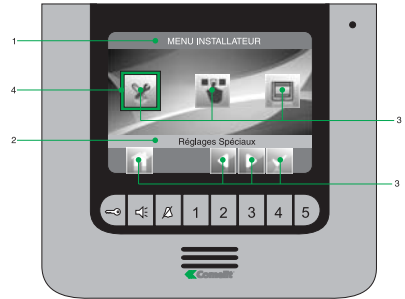

- 1 Titre menu actuellement ouvert.
- 2 Titre menu sélectionné.
- 3 Icônes menu.
- 4 Cadre indiquant le menu sélectionné.
- 5 Icônes fonction associées aux touches.

**19**

**DESCRIPTION ICÔNES ASSOCIÉES AUX TOUCHES**

Les icônes déterminent la fonction exercée par le touche situé dessous comme décrit ci-après :

- Permet de reculer d'un niveau ou de quitter le menu.
- Permet d'ouvrir / confirmer le menu sélectionné.
- Permet de retourner au menu principal.
- 

Permet de se déplacer à l'intérieur du menu / d'augmenter et de diminuer une valeur sélectionnée.

## 20 CONFIGURATION MOT DE PASSE MODEM

Depuis le menu d'installation (touche 1) accéder au menu "Configurer moniteur" avec **[F5]** et **[F4]**.

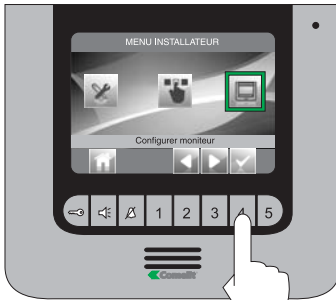

Accéder au menu "Configurer bride".

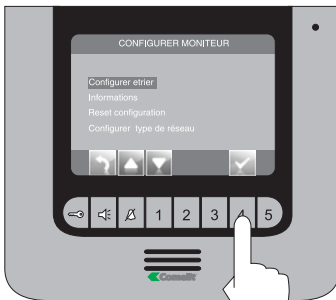

Accéder au menu "Changer mot de passe".

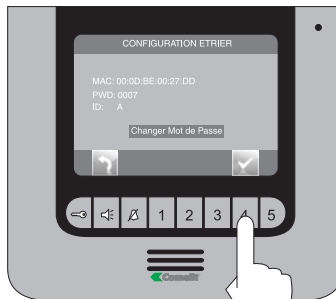

Saisir le mot de passe du pont relié à l'habitation concernée (point 14C) en modifiant le numéro sélectionné avec les touches **[F5]** et **[F4]**. Pour passer au numéro suivant ou précédent, utiliser les touches **[F5]**.



Appuyer sur la touche **[F5]** pour quitter et enregistrer les modifications.

Lorsque les opérations de configuration sont terminées, invalider le menu d'installation.

## 21 SIGNALISATION ANOMALIES ET SOLUTIONS POSSIBLES

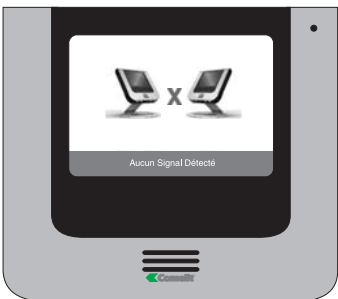

En cas de connexion non réussie avec le poste intérieur, attendre 1 minute. Si la signalisation se présente à nouveau, vérifier :

- que le moniteur secondaire a la même adresse que le moniteur principal de l'habitation concernée (point 14A).
- que le moniteur principal est alimenté (point 11).
- que le mot de passe correct a été saisi (point 14C et 20).
- que les distances d'installation ont été respectées (point 8).



En cas de connexion absente avec la plaque de rue, vérifier :

- que la plaque de rue est correctement câblée (point 2) et qu'elle est alimentée (point 8).
- que le pont Art. 1398 est correctement câblé (point 7A, 7B, 7C).
- qu'il y a correspondance entre le mot de passe du pont Art. 1398 et l'alimentateur moniteur de la même habitation.
- que les distances d'installation ont été respectées (point 8).

## 22 CONFIGURATION TOUCHES

Le kit dispose de 2 relais (relais 1 et relais 2) pour chaque plaque de rue reliée.

Il est possible d'en configurer le fonctionnement tant durant qu'en absence d'appel (installation au repos). Avec chaque touche configuré pour la commande des relais, il est possible d'activer simultanément 2 relais\* au maximum.

En cas d'appel, l'un des relais activable est nécessairement celui de la porte qui appelle.

### • TOUCHE CLÉ →

Depuis le menu d'installation (touche 1) accéder au menu "Configurer touches" avec et .



sélectionner l'icône "Configurer Touche Clé" avec les touches et et confirmer le choix en appuyant sur .

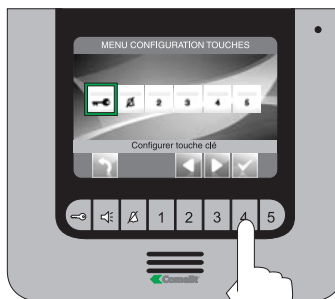

\* En cas d'activation simultanée de 2 relais, disposer pour une des charges un alimenteur dédié.

Sélectionner le mode pour lequel on désire modifier la fonction avec les touches **↔** et confirmer le choix en appuyant sur **↵**.

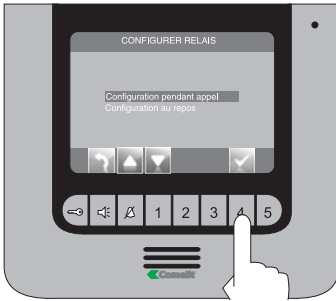

Sélectionner les champs modifiables avec les touches **↔** et modifier la valeur avec **↵** ou **↶**.



Sélectionner les champs modifiables avec les touches **↔** et modifier la valeur avec **↵** ou **↶**.



Appuyer sur le touche **↵** pour quitter et enregistrer les modifications.

Lorsque les opérations de configuration sont terminées, invalider le menu d'installation.

• **TOUCHE PRIVACY / DOCTEUR** **↵**

- La fonction Privacy permet d'exclure l'appel depuis la plaque de rue ou poste intercommunicant.
- La fonction Docteur permet l'activation automatique de l'ouvre porte (relais 1) sur appel depuis plaque de rue.
- La fonction Docteur + Privacy non seulement permet de désactiver la sonnerie de l'interphone comme dans la fonction Privacy, mais en plus elle permet l'actionnement automatique de l'ouvre porte (relais 1) sur appel depuis plaque de rue.

Depuis le menu d'installation (touche 1), accéder au menu "Configurer touches" avec **↵** et **↵**.



Sélectionner l'icône "Configurer privacy /docteur" avec les touches **↵** et confirmer le choix en appuyant sur **↵**.

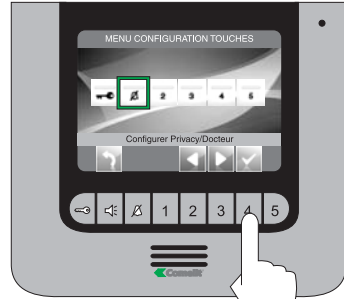

Sélectionner la fonction désirée avec les touches **↵** et confirmer le choix en appuyant sur **↵**.

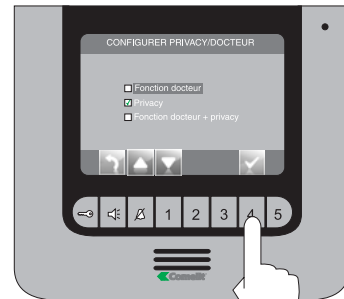

Lorsque les opérations de configuration sont terminées, invalider le menu d'installation.

• **TOUCHES 2 - 3 - 4 - 5**

Les touches 2, 3, 4 et 5 peuvent être tous programmés avec la même procédure. Ci-dessous, illustration de la programmation du touche 2.

Depuis le menu d'installation (touche 1), accéder au menu "Configurer touches" avec et .



Sélectionner l'icône "Configurer Touche2" avec les touches et confirmer le choix en appuyant sur .

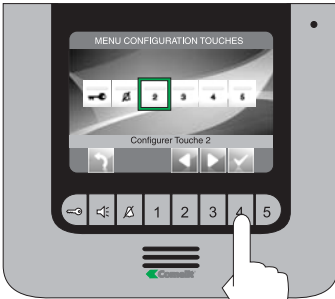

Sélectionner la fonction désirée avec les touches , confirmer le choix en appuyant sur et appuyer ensuite sur la touche .

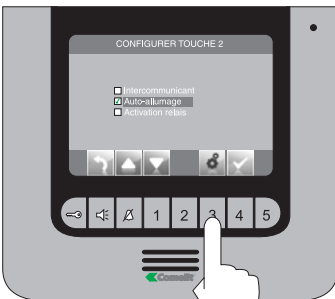

Si la fonction "Intercommunicant" a été sélectionnée dans le passage précédent, associer le touche à un poste intérieur.

INTERCOM X (voir point 14 B).

**GÉNÉRAL INTERNE** : envoie un appel à tous les moniteurs de la même habitation.

**GÉNÉRAL EXTERNE** : envoie un appel à tous les moniteurs de l'autre habitation.

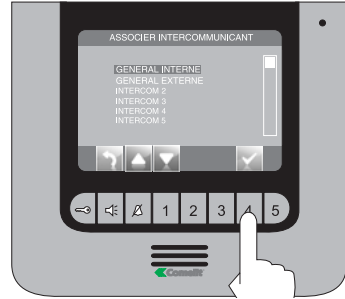

Si la fonction "Auto-allumage" a été sélectionnée dans le passage précédent, il faut associer le touche à une ou aux deux plaques de rue.

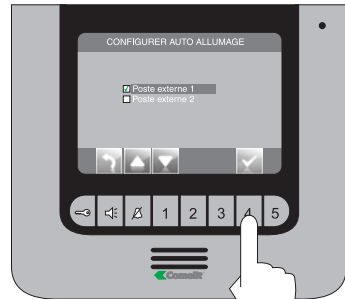

Si la fonction "Activation relais" a été sélectionnée dans le passage précédent, suivre la procédure indiquée pour la programmation du Touche clé

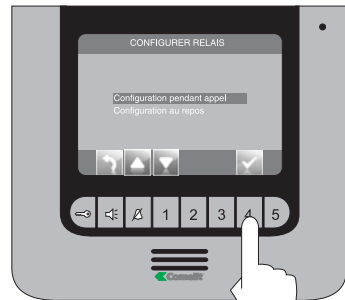

Appuyer sur la touche pour quitter et enregistrer les modifications.

Lorsque les opérations de configuration sont terminées, invalider le menu d'installation.

## 23 ACTIVATION RÉPÉTITION SONNERIE

Avec cette fonction active, le moniteur répètera la sonnerie trois fois après la réception d'un appel

Depuis le menu d'installation (touche 1), accéder au menu "Réglages spéciaux" avec **4**, **2** et **4**.



Accéder au menu "Configurer répétition sonnerie"

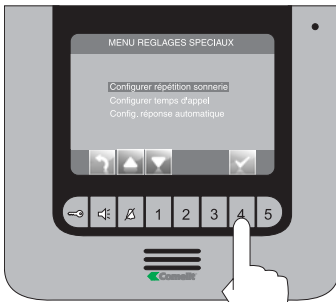

Confirmer le choix en appuyant sur **4**

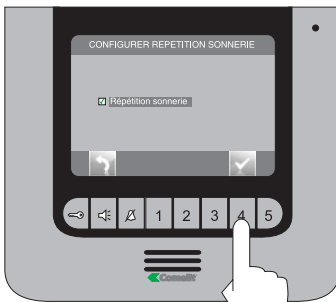

Appuyer sur le touche **4** pour quitter et enregistrer les modifications.

Lorsque les opérations de configuration sont terminées, invalider le menu d'installation.

## 24 ACTIVATION RÉPONSE AUTOMATIQUE

Avec cette fonction programmée, la fonction phonique est automatiquement activée après la réception d'un appel

Depuis le menu d'installation (touche 1), accéder au menu "Réglages spéciaux" avec **4**, **2** et **4**.

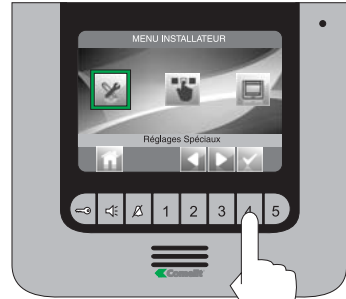

Accéder au menu "Réponse automatique"

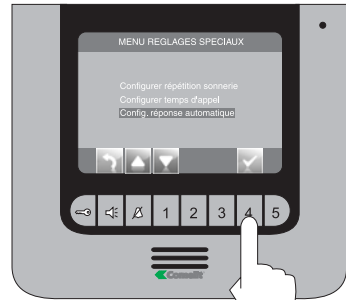

Confirmer le choix en appuyant sur **4**





Appuyer sur le touche **4** pour quitter et enregistrer les modifications.

Lorsque les opérations de configuration sont terminées, invalider le menu d'installation.

25

## VISUALISER INFORMATIONS

Depuis le menu d'installation (touche 1), accéder au menu "Configurer moniteur" avec  et .

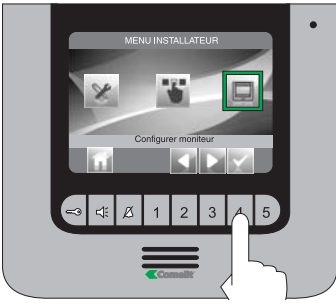

Accéder au menu "Informations"

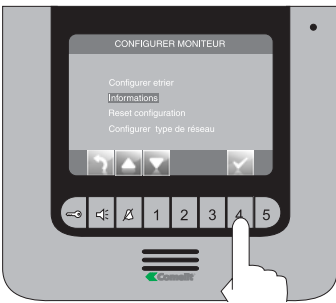



Lorsque les opérations de configuration sont terminées, invalider le menu d'installation.

26

## CONFIGURATION TEMPS D'APPEL

Dans ce menu, il est possible de modifier :



- Temps d'attente réponse : temps maximum au-delà duquel la communication se termine en absence de réponse
- Temps conversation : durée d'une conversation entre poste intérieur et plaque de rue
- Temps conversation intercom : durée d'une conversation intercommunicante
- Retard d'extinction : après un appel, temps d'attente depuis l'activation d'un relais jusqu'à l'extinction du moniteur.

Depuis le menu d'installation (touche 1), accéder au "Réglages spéciaux" avec  et .



Accéder au menu "Configurer temps d'appel"



Sélectionner la valeur que l'on veut modifier avec les touches  et  et confirmer le choix en appuyant sur .

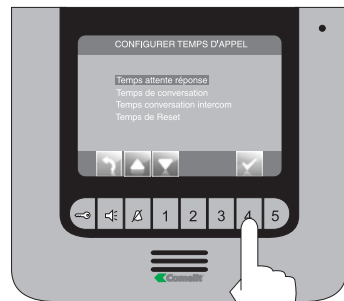



Modifier la valeur avec les touches   





Appuyer sur la touche  pour quitter et enregistrer les modifications.

Lorsque les opérations de configuration sont terminées, invalider le menu d'installation.



**27**

## RESET CONFIGURATION

**Cette opération rétablira tous les réglages d'usine, en annulant toutes les modifications apportées**

Depuis le menu d'installation (touche 1), accéder au menu "Configurer moniteur" avec   et .



Sélectionner le menu "reset configuration" avec les touches  .

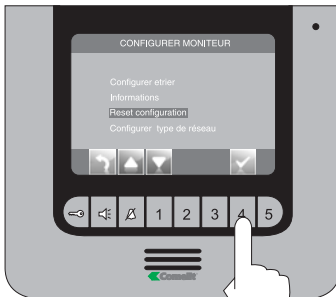

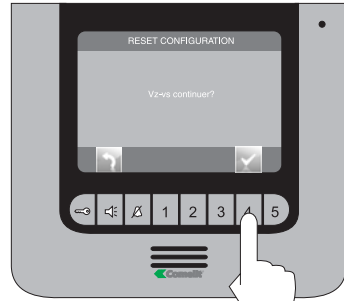

Confirmer le choix en appuyant sur .



**28**

## MENU PROGRAMMATION TYPE DE RÉSEAU

Depuis le menu d'installation (touche 1), accéder au menu "Configurer moniteur" avec   et .

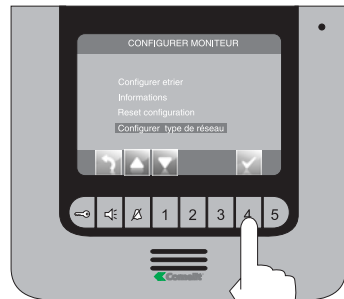

**NE MODIFIER EN AUCUN CAS CETTE VALEUR.**

La valeur programmée par défaut est IPOWERR.

- IT** Cablaggio kit monofamiliare Art. 8591.
- EN** Wiring for single-residence kit Art. 8591.
- FR** Câblage kit un appartement Art. 8591.

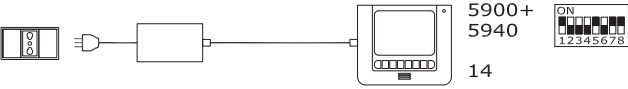

①

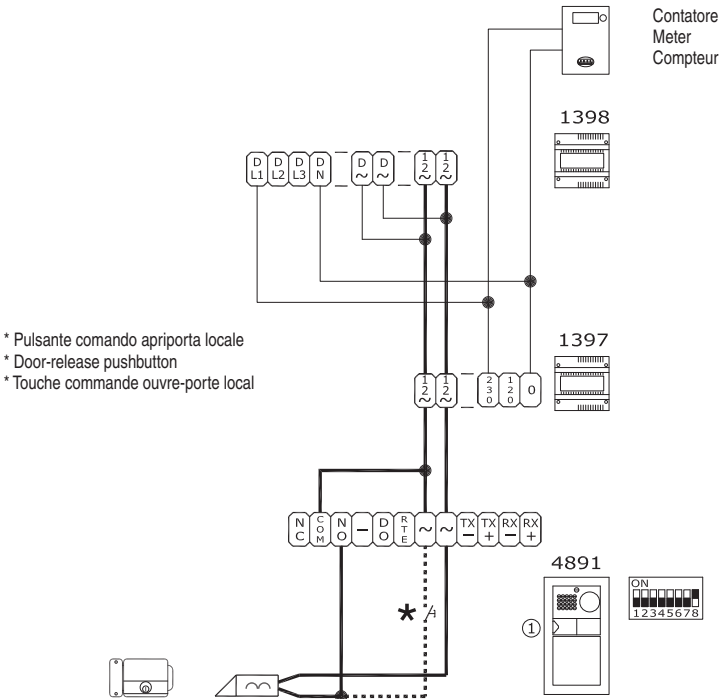
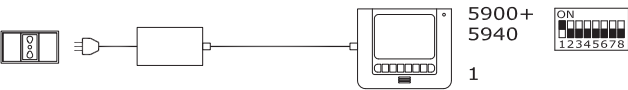
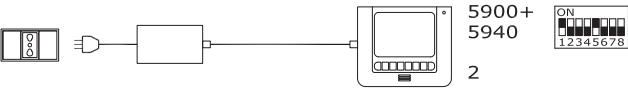

- \* Pulsante comando apriporta locale
- \* Door-release pushbutton
- \* Touche commande ouvre-porte local

## PWK/05

- IT** Cablaggio kit monofamiliare trifase Art. 8591.
- EN** Wiring for three-phase single-residence kit Art. 8591.
- FR** Câblage kit un appartement triphasé Art. 8591.

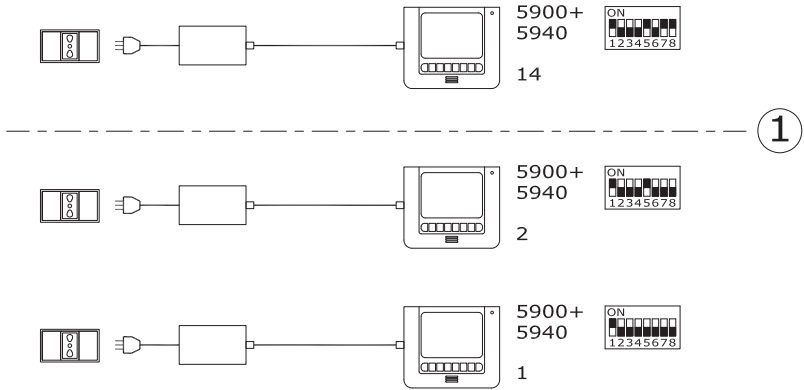

Contatore  
Meter  
Compteur

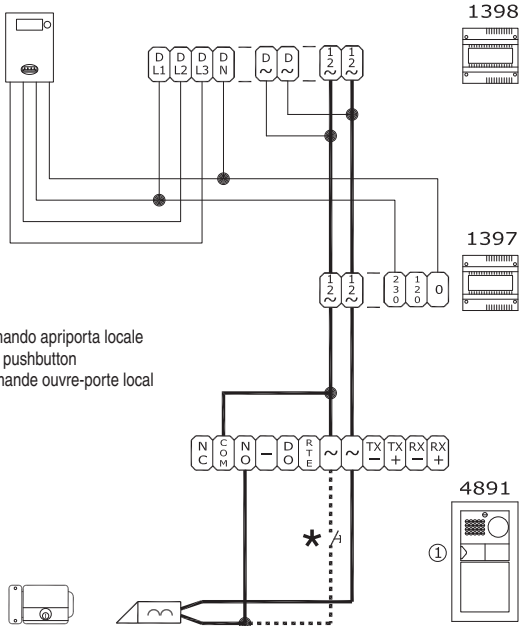

- \* Pulsante comando apriporta locale
- \* Door-release pushbutton
- \* Touche commande ouvre-porte local

**PWK/02A**

- IT** Cablaggio kit bifamiliare Art. 8592.
- EN** Wiring for two-residence kit Art. 8592.
- FR** Câblage kit deux appartements Art. 8592.

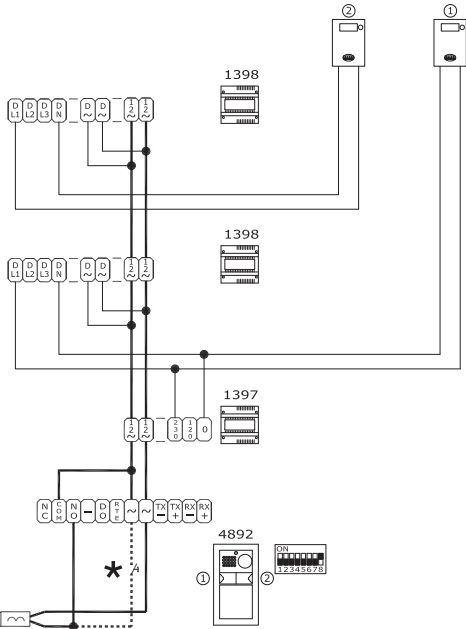
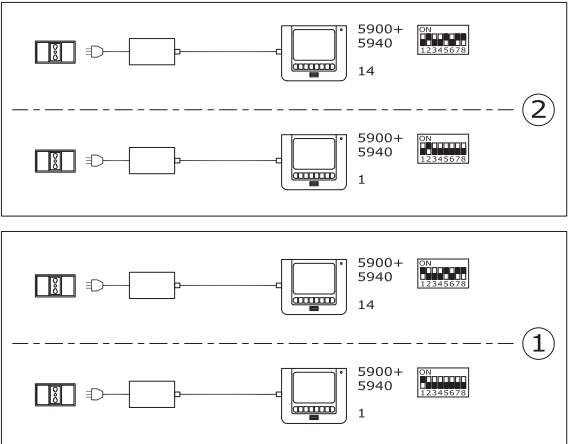

Contatore  
Meter  
Compteur

- \* Pulsante comando apriporta locale
- \* Door-release pushbutton
- \* Touche commande ouvre-porte local

## PWK/06

- IT** Cablaggio kit bifamiliare trifase Art. 8592.
- EN** Wiring for three-phase two-residence kit Art. 8592.
- FR** Câblage kit deux appartement triphasé Art. 8592.

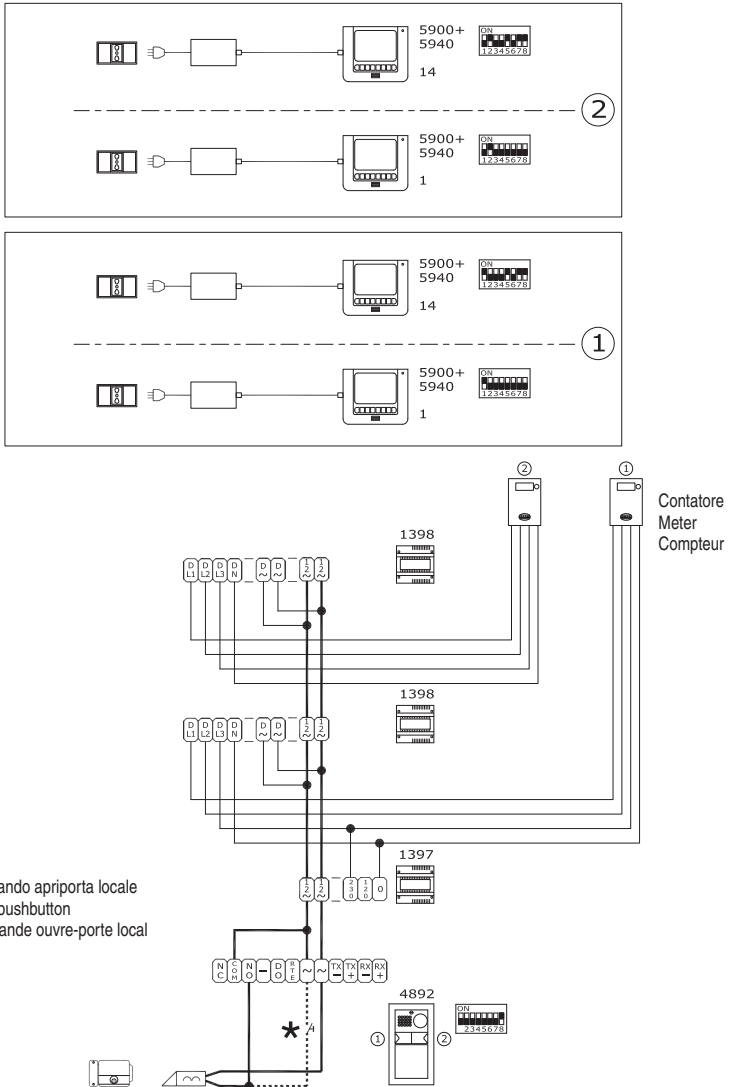

**PWK/02B**

- (IT)** Cablaggio kit bifamiliare Art. 8592 con contatore parti comuni.
- (EN)** Wiring for two-residence kit Art. 8592 with shared parts meter.
- (FR)** Câblage kit deux appartements Art. 8592 ave compteur parties communes.

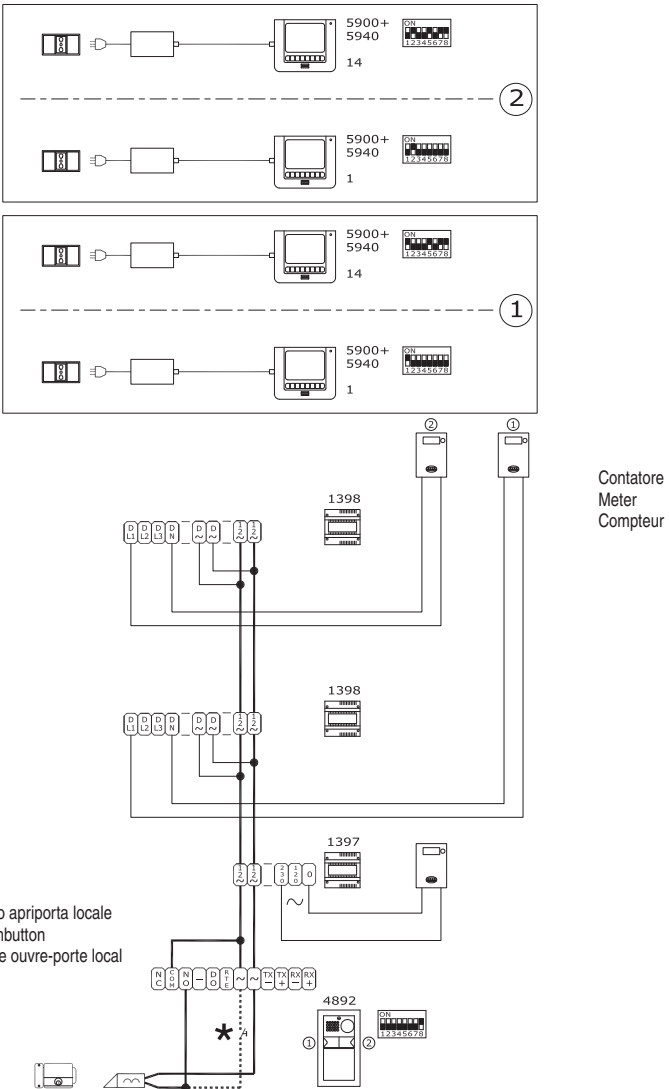

Contatore  
Meter  
Compteur

## PWK/01B

- IT** Cablaggio kit monofamiliare con alimentatore supplementare per posto esterno.
- EN** Wiring for single-residence kit with additional external unit power supply.
- FR** Câblage kit un appartement avec alimentateur supplémentaire pour plaque de rue.



5900+  
5940  
14

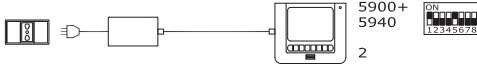

5900+  
5940  
2



5900+  
5940  
1

1

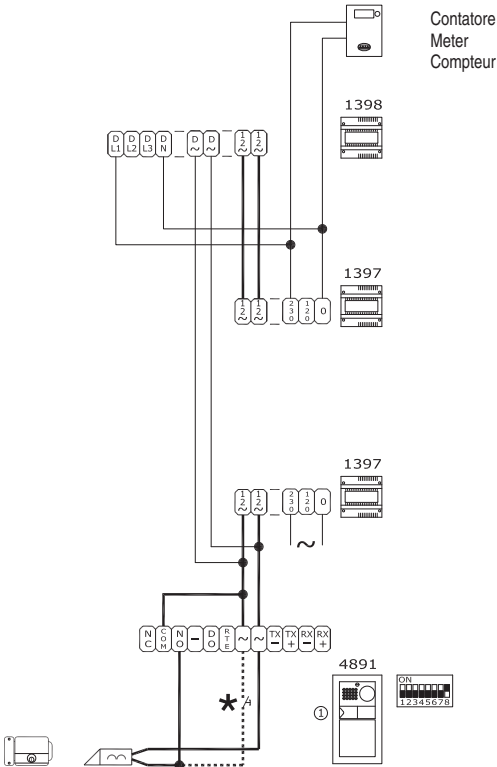

Contatore  
Meter  
Compteur

1398

1397

1397

4891

- \* Pulsante comando apriporta locale
- \* Door-release pushbutton
- \* Touche commande ouvre-porte local

PWK/03

- IT** Cablaggio kit monofamiliare con 2 posti esterni.
- EN** Wiring for single-residence kit with 2 external units.
- FR** Câblage kit un appartement avec 2 plaques de rue.

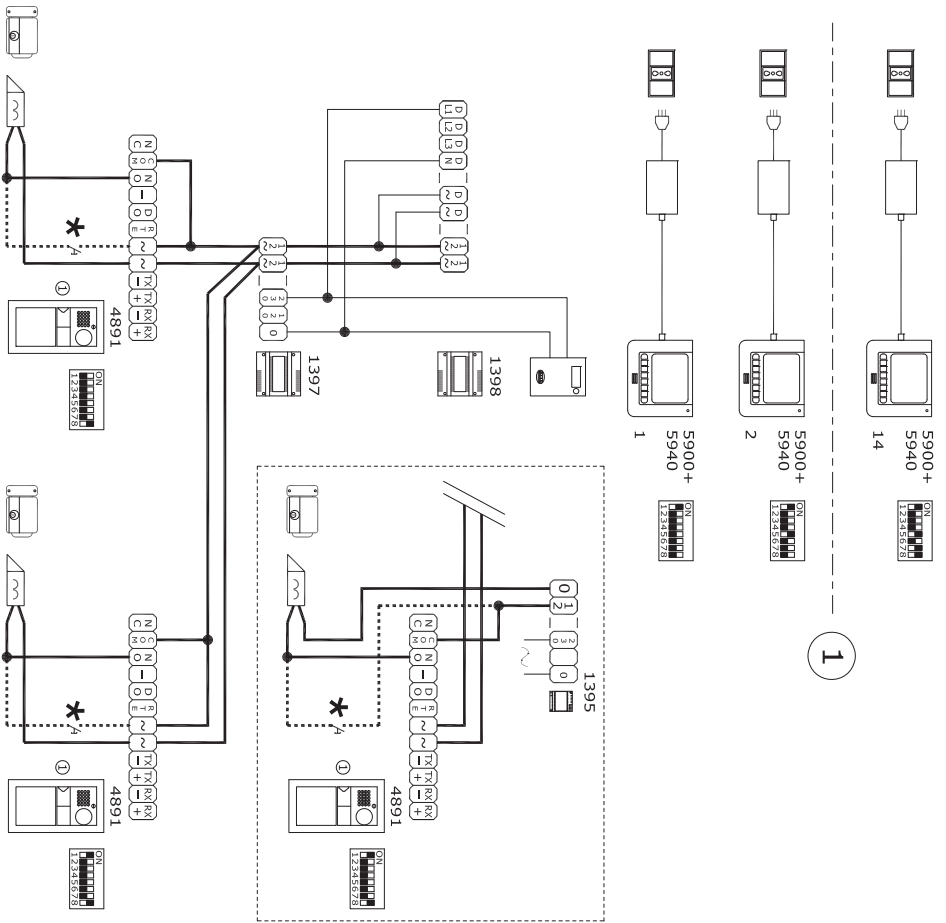

- \* Pulsante comando apertura locale
- \* Door-release pushbutton
- \* Touche commande ouvre-porte local

Serratura da alimentare a parte se attivata contemporaneamente a quella dell'altro posto esterno  
 Door-release device to be powered separately if activated at the same time as the device for the other external unit.  
 Gâche à alimenter à part si activée simultanément à celle de l'autre plaque de rue



## PWK/04

- IT** Cablaggio kit bifamiliare con 2 posti esterni.
- EN** Wiring for Two-residence kit with 2 external units.
- FR** Câblage kit deux appartements avec 2 plaques de rue.

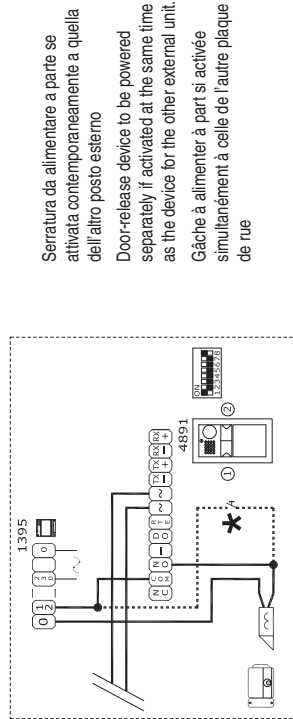
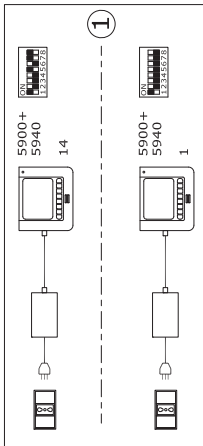
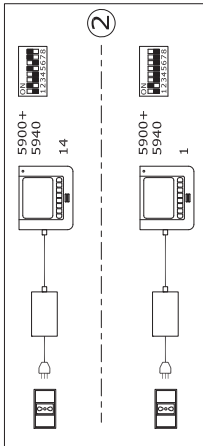

Serratura da alimentare a parte se attivata contemporaneamente a quella dell'altro posto esterno

Door-release device to be powered separately if activated at the same time as the device for the other external unit.

Gâche à alimenter à part si activée simultanément à celle de l'autre plaque de rue

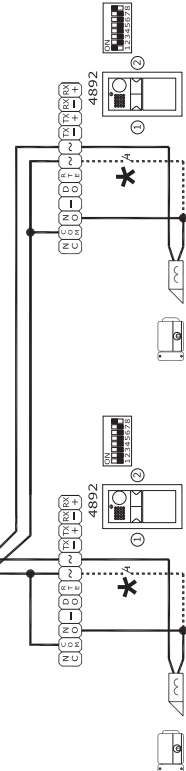

- \* Pulsante comando aprir/porta locale
- \* Door-release pushbutton
- \* Touche commande ouvre-porte local

**PW/AAA**

- IT** Variante collegamento relé del modulo numero civico (relé 2). Vedi punto 13
- EN** Variant with house number module relay connection (relay 2). See paragraph 13
- FR** Variante connexion relais du module numéro de rue (relais 2). Voir point 13

- \* Vedi tabella programmazione posto esterno per uso relé numero 2. Vedi punto 6
- \* See table - programming external unit for use with relay number 2. See paragraph 6
- \* Voir tableau programmation plaque de rue pour emploi relais numéro 2. Voir point 6

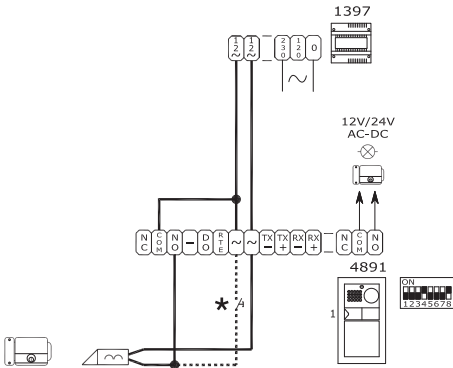

Contatto libero 12-24 V AC/DC Max 2A  
Utilizzare un alimentatore dedicato

Free contact 12-24 V AC/DC Max 2A  
Use a special power supply

Contact libre 12-24 V CA/CC Max 2A  
Utiliser un alimentateur spécial

**PW/AAB**

- IT** Variante collegamento relé temporizzato.
- EN** Variant with timed relay connection (Request to exit).
- FR** Variante connexion relais temporisé.

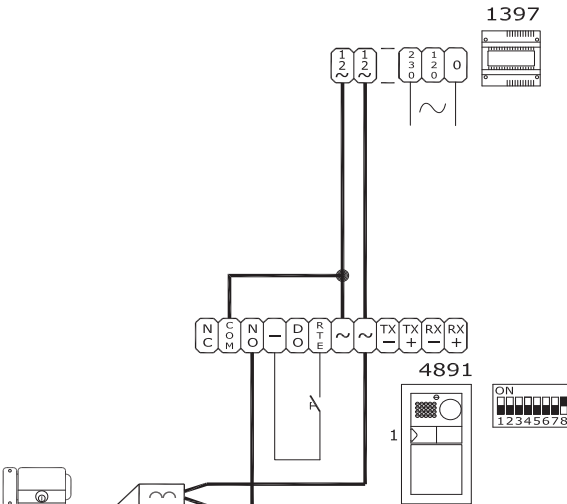

## PW/AAC

- IT** Variante contatto segnalazione porta aperta.
- EN** Variant with door open indication contact.
- FR** Variante contact signalisation porte ouverte.

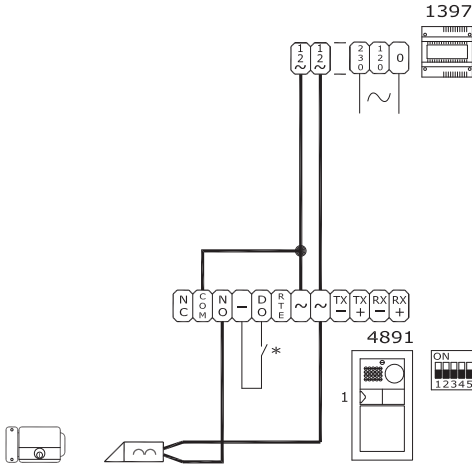

Contatto N.C. per segnalazioni PORTA APERTA  
 N.C. contact for DOOR OPEN signalling  
 Contact N.F. pour signalisation PORTE OUVERTE

- IT** Variante per utilizzo rete RC per filtro serratura sui contatti del relé 1 o relé 2.
- EN** Variant using RC network for door-release filter on relay 1 or relay 2 contacts.
- FR** Variante pour emploi réseau RC pour filtre gâche sur contacts du relais 1 ou relais 2.

Sui contatti COM. NC.  
 On contacts COM. NC.  
 Sur les contacts COM. NC.

Sui contatti COM. NO.  
 On contacts COM. NO.  
 Sur les contacts COM. NO.

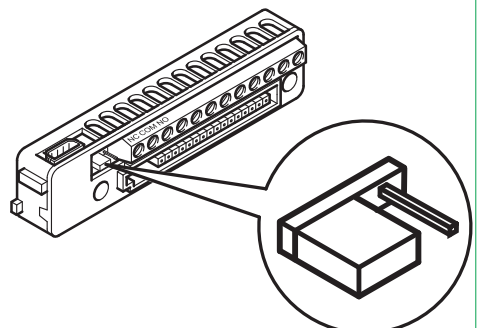
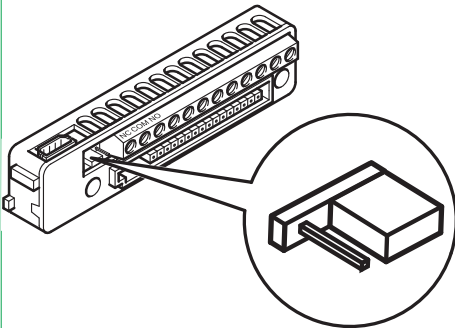

**Assistenza tecnica Italia** 0346/750090  
**Commerciale Italia** 0346/750091

**Technical service abroad** (+39) 0346750092  
**Export department** (+39) 0346750093



**[ GR ] Comelit Hellas**

9 Epiru str.  
 16452 Argyroupolis - Athens Greece  
 Tel. +30 210 9968605-6 -  
 Fax +30 210 9945560  
 www.comelit.gr  
 telergo@otenet.gr

**[ RC ] Comelit (Shanghai) Electronics Co., Ltd**  
 5 Floor No. 4 Building No.30 Hongcao Road  
 Hi-Tech Park Caohejing, Shanghai, China  
 Tel. +86-21-64519192/93773527  
 Fax. +86-21-64517710  
 www.comelit.com.cn  
 comelit@comelit.com.cn

**[ B ] Comelit Group Belgium**

Z.3 Doornveld 170  
 1731 Zelk ( Asse )  
 Tel. +32 (0) 24115099 -  
 Fax +32 (0) 24115097  
 www.comelit.be - info@comelit.be

**[ I ] Comelit Piemonte**

Str. Del Pascolo 6/E - 10156 Torino  
 Tel. e Fax +39 011 2979330  
 www.comelit.eu  
 gino.bruccheri@comelit.it  
 roberto.tani@comelit.it  
 luca.merlo@comelit.it

**[ SG ] Comelit Group**

Singapore Representative Office  
 54 Genting Lane, Ruby Land Complex  
 Bld 2, #06-01 - Singapore 349562  
 Tel. +65-6748 8563 - Fax +65-6748 8584  
 office@comelit.sg

**[ D ] Comelit Group Germany GmbH**

Brüsseler Allee 23- 41612 Erkelzen  
 Tel. +49 (0) 243190151-23  
 +49 (0) 243190151-24  
 Fax +49 (0) 24319015125  
 www.comelit.de - info@comelit.de

**[ I ] Comelit Sud S.r.l.**

Via Corso Claudio, 18  
 84063 Castel San Giorgio (Sa)  
 Tel. +39 081 516 2021  
 Fax +39 081 953 5951  
 www.comelit.eu - info@comelitsud.it

**[ UAE ] Comelit Group U.A.E.**

Middle East Office  
 P.O. Box 54433 - Dubai U.A.E.  
 Tel. +971 4 299 7533 - Fax +971 4 299 7534  
 www.scame.ae  
 scame@scame.ae

**[ E ] Comelit Espana S.L.**

Josep Estivill 67/69 - 08027 Barcelona  
 Tel. +34 932 430 376 - Fax +34 934 084 683  
 www.comelit.es  
 info@comelit.es

**[ IRL ] Comelit Ireland**

Suite 3 Herbert Hall  
 16 Herbert Street - Dublin 2  
 Tel. +353 (0) 1 619 0204  
 Fax +353 (0) 1 619 0298  
 www.comelit.ie  
 info@comelit.ie

**[ LUK ] Comelit Group UK Ltd**

Unit 4 Mallow Park - Watchmead Welwyn  
 Garden City Herts - AL7 1GX  
 Tel: +44 (0)1707377203  
 Fax: +44 (0)1707377204  
 www.comelitgroup.co.uk  
 info@comelitgroup.co.uk

**[ F ] Comelit Immoctec**

Siege:  
 Parc d'activités Technologiques EUROPARC  
 3, Allées des Saules - 94042 CRETEIL CEDEX  
 Tel. +33 (0) 1 43 53 97 97 - Fax +33 (0) 1 43 53 97 87  
 Centre logistique livraisons - commandes  
 15, Rue Jean Zay - 69800 SAINT PRIEST  
 Tel. +33 (0) 4 72 28 06 56 - Fax +33 (0) 4 72 28 83 29  
 www.comelit.fr - comelit.NH@wanadoo.fr

**[ NL ] Comelit Nederland BV**

Aventurinjn 220-3316 LB Dordrecht  
 Tel. +31 (0) 786511201 - Fax +31 (0) 786170955  
 www.comelit.nl - info@comelit.nl

**[ USA ] Comelit Cyrex**

250 W. Duarte Rd. Suite B  
 Monrovia, CA 91016  
 Tel. +1 626 930 0388 - Fax +1 626 930 0488  
 www.comelitusa.com  
 sales@cyrexnetworks.com